

Service
Service
Service

DVD620 /001 /021 /051
DVD623 /001 /021 /051
DVD633 /001 /021 /051



CL 16532162_000.eps
070102

Service Manual



Contents	Page
1 Technical Specs and Connection Facilities	2
2 Safety Instructions, Warnings, Notes, and Service Hints	3
3 Directions for Use	6
4 Mechanical- and Dismantling Instructions	16
5 Diagnostic Software, Trouble Shooting and Test Instructions	18
6 <i>Wiring-, Block Diagrams</i>	
Block Diagram	37
Wiring Diagram	38
7 <i>Electrical Diagrams and Print-Layouts</i>	<i>Diagram PWB</i>
Power Supply Unit	39 40
AV Board: Video & SCART	(Diagram A1) 41 45-51
AV Board: Audio	(Diagram A2) 42 45-51
AV Board: Front	(Diagram A3) 43 45-51
AV Board: Regulated Supply	(Diagram A4) 44 45-51
Front Controls	(Diagram C) 52 52
Front Standby-On	(Diagram S) 52 52
8 Alignments	(Not Applicable) 53
9 Circuit-, IC Descriptions, and List of Abbreviations	53 56
10 Spare Parts List	58

©Copyright 2002 Philips Consumer Electronics B.V. Eindhoven, The Netherlands.
All rights reserved. No part of this publication may be reproduced, stored in a
retrieval system or transmitted, in any form or by any means, electronic,
mechanical, photocopying, or otherwise without the prior permission of Philips.



PHILIPS

1. Technical Specifications & Connection Facilities

Specifications

PLAYBACK SYSTEM

DVD Video
Video CD & SVCD
CD (CD-Recordable and CD-Rewritable)

TV STANDARD (PAL/50Hz) (NTSC/60Hz)

Number of lines	625	525
Playback	Multistandard	(PAL/NTSC)

VIDEO PERFORMANCE

Video output	1Vpp into 75 ohm
RGB (SCART) output	0.7Vpp into 75 ohm
Black Level Shift	On/Off
Video Shift	Left/Right

AUDIO FORMAT

Digital	MPEG	Compressed Digital
	Dolby Digital	16, 20, 24 bits
	PCM	fs, 44.1, 48 kHz

Analogue Stereo Sound
Dolby Surround-compatible downmix from Dolby Digital multi-channel sound
3D Sound for virtual 5.1 channel sound on 2 speakers

AUDIO PERFORMANCE

DA Converter	24 bits	
DVD	fs 96 kHz	4 Hz - 22 kHz
	fs 48 kHz	4 Hz - 22 kHz
CD/VCD	fs 44.1 kHz	4 Hz - 20 kHz
SVCD	fs 48 kHz	4 Hz - 22 kHz
	fs 44.1 kHz	4 Hz - 20 kHz
Signal-Noise (1kHz)		110 dB
Dynamic Range (1kHz)		95 dB
Crosstalk (1kHz)		110 dB
Distortion and Noise (1kHz)		90 dB

CONNECTIONS

SCART	Euroconnector
Video Output	Cinch (yellow)
Audio L+R output	Cinch (white/red)
Digital Output	1 coaxial
	IEC958 for CDDA / LPCM
	IEC1937 for MPEG1/2 / Dolby Digital

CABINET

Dimensions (w x h x d)	435 x 75 x 210.5 mm
Weight	Approximately 1.9 Kg

* typical playing time for movie with 2 spoken languages and 3 subtitle languages

Specifications subject to change without prior notice

Maintenance

Cleaning the Cabinet

- Use a soft cloth slightly moistened with a mild detergent solution. Do not use a solution containing alcohol, spirits, ammonia or abrasives.

Cleaning Discs

- When a disc becomes dirty, clean it with a cleaning cloth. Wipe the disc from the centre out. Do not wipe in a circular motion.
- Do not use solvents such as benzine, thinner, commercially available cleaners, or antistatic spray intended for analogue records.

Cleaning the disc lens

- After prolonged use, dirt or dust may accumulate at the disc lens. To ensure good playback quality, clean the disc lens with Philips CD Lens Cleaner or any commercially available cleaner. Follow the instructions supplied with the cleaner.

2. Safety Instructions, Warnings, Notes, and Service Hints

2.1 Safety Instructions

2.1.1 General Safety

Safety regulations require that during a repair:

- Connect the unit to the mains via an isolation transformer.
- Replace safety components, indicated by the symbol ▲, only by components identical to the original ones. Any other component substitution (other than original type) may increase risk of fire or electrical shock hazard.

Safety regulations require that after a repair, you must return the unit in its original condition. Pay, in particular, attention to the following points:

- Route the wires/cables correctly, and fix them with the mounted cable clamps.
- Check the insulation of the mains lead for external damage.
- Check the electrical DC resistance between the mains plug and the secondary side:
 1. Unplug the mains cord, and connect a wire between the two pins of the mains plug.
 2. Set the mains switch to the 'on' position (keep the mains cord unplugged!).
 3. Measure the resistance value between the mains plug and the front panel, controls, and chassis bottom.
 4. Repair or correct unit when the resistance measurement is less than 1 MΩ.
 5. Verify this, before you return the unit to the customer/user (ref. UL-standard no. 1492).
 6. Switch the unit 'off', and remove the wire between the two pins of the mains plug.

2.1.2 Laser Safety

This unit employs a laser. Only qualified service personnel may remove the cover, or attempt to service this device (due to possible eye injury).

Laser Device Unit

Type	: Semiconductor laser GaAlAs
Wavelength	: 650 nm (DVD) 780 nm (VCD/CD)
Output Power	: 20 mW (DVD+RW writing) 0.8 mW (DVD reading) 0.3 mW (VCD/CD reading)
Beam divergence	: 60 degree

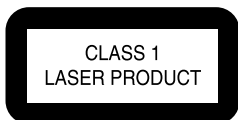

Figure 2-1

Note: Use of controls or adjustments or performance of procedure other than those specified herein, may result in hazardous radiation exposure. Avoid direct exposure to beam.

2.2 Warnings

2.2.1 General

- All ICs and many other semiconductors are susceptible to electrostatic discharges (ESD, ⚡). Careless handling during repair can reduce life drastically. Make sure that, during repair, you are at the same potential as the mass of the set by a wristband with resistance. Keep components and tools at this same potential.

Available ESD protection equipment:

- Complete kit ESD3 (small tablemat, wristband, connection box, extension cable and earth cable) 4822 310 10671.
- Wristband tester 4822 344 13999.
- Be careful during measurements in the live voltage section. The primary side of the power supply (pos. 1005), including the heatsink, carries live mains voltage when you connect the player to the mains (even when the player is 'off!'). It is possible to touch copper tracks and/or components in this unshielded primary area, when you service the player. Service personnel must take precautions to prevent touching this area or components in this area. A 'lightning stroke' and a stripe-marked printing on the printed wiring board, indicate the primary side of the power supply.
- Never replace modules, or components, while the unit is 'on'.

2.2.2 Laser

- The use of optical instruments with this product, will increase eye hazard.
- Only qualified service personnel may remove the cover or attempt to service this device, due to possible eye injury.
- Repair handling should take place as much as possible with a disc loaded inside the player.
- Text below is placed inside the unit, on the laser cover shield:

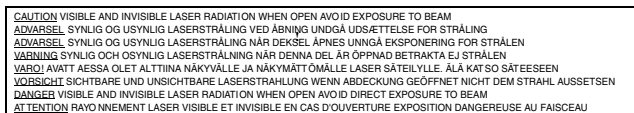

Figure 2-2

2.2.3 Notes

Dolby

Manufactured under licence from Dolby Laboratories. "Dolby", "Pro Logic" and the double-D symbol are trademarks of Dolby Laboratories. Confidential Unpublished Works. ©1992-1997 Dolby Laboratories, Inc. All rights reserved.



Figure 2-3

Trusurround

TRUSURROUND, SRS and symbol (fig 2-4) are trademarks of SRS Labs, Inc. TRUSURROUND technology is manufactured under licence from SRS Labs, Inc.



Figure 2-4

2.3 Service Hints

2.3.1 Switched Mode Power Supply

This power supply unit has to be repaired down to component level in case of failure.

2.3.2 DVD Module

This module can be repaired as follows:

1. The VAL6013/01 is a combination of loading mechanism and DVD-mechanism. Both are not repairable units and in case of failure, it has to be replaced with a new loader VAL6013/01.

Note: When replacing with a new VAL6013/01 and DVD mechanism, two solder joints have to be removed after connecting the OPU flex foil to the mono board. The solder joints, which shortcircuits the laser diodes to ground, are for protection against ESD. Refer to figures 2-5 and 2-6 for location of solder joints.

2. The mono board has to be repaired down to component level. Repair handling of the monoboard requires a workshop with sophisticated desoldering tools.

VAL6013/01 Solder Joints

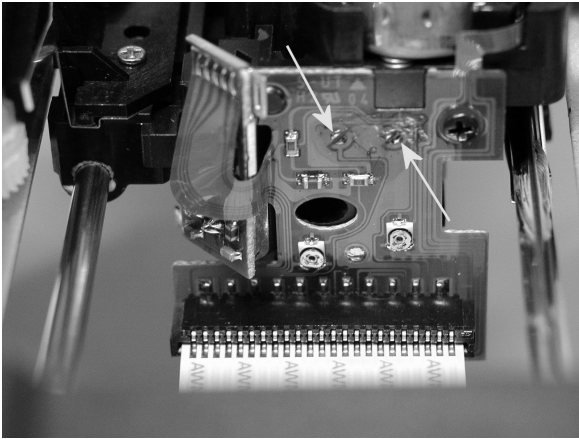

Figure 2-5

VAL6013/01 Solder Joints

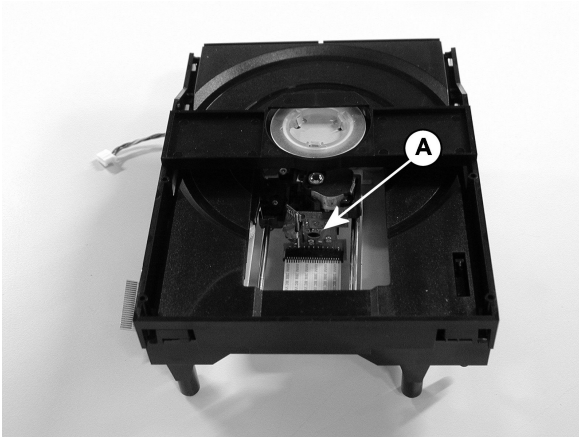

Figure 2-6

2.3.3 ComPair

For assistance with the repair process of the monoboard an electronic fault finding guidance has been developed. This program is called ComPair.

This ComPair program is available on CDROM. The version of the CDROM for repair of the monoboard is V1.3 or higher and can be ordered with codenumber 4822 727 21637. This is an update CDROM, so when the ComPair CDROM is used for the first time, one has to install the ComPair Engine CDROM V1.2 first.

The V1.2 CDROM can be ordered with code number 4822 727 21634 and has to be registered after installation. The procedure for registration is explained in the help file of the program and in the CDROM booklet.

The cable to connect the monoboard with a PC can be ordered with codenumber: 3122 785 90017.

All the hardware and software requirements of the systems, necessary for working with ComPair, are described on the CDROM.

2.3.4 Service Positions

Refer to dismantling instructions for dismantling of the board. Figures 2-7 to 2-9 shows the service position that are recommended during repair of the boards.

Mono Board

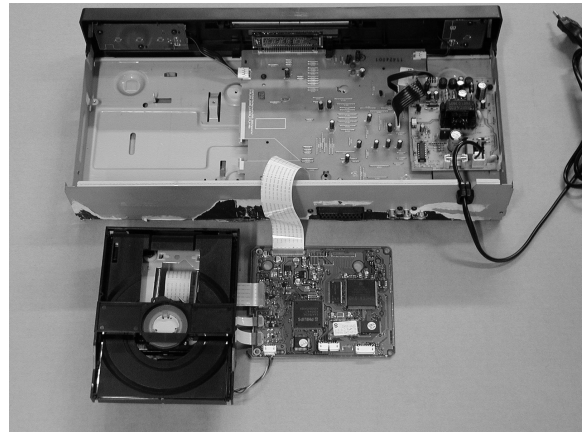

Figure 2-7

Mono Board

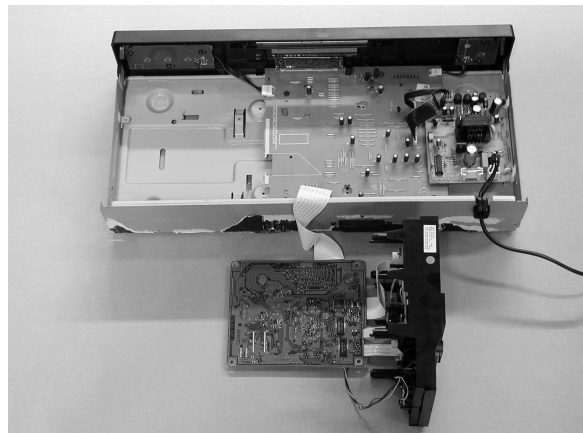

Figure 2-8

Mother Board

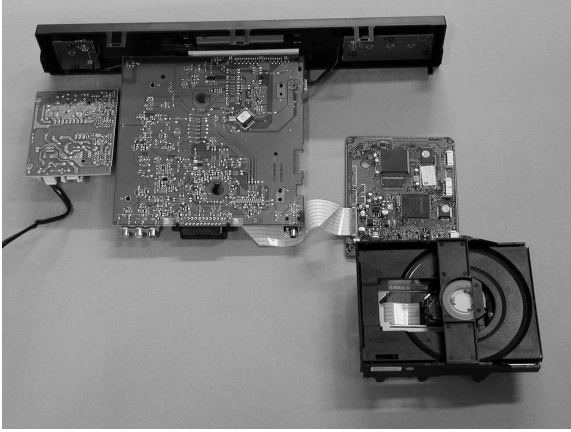

Figure 2-9

3. Directions for Use

Contents

Introduction	
Environmental Information	6
Supplied accessories	6
Safety Information	6
Symbols Used in this Manual	6
Functional Overview	
Front and Rear Panels	7
Remote Control	8
Preparation	
Basic Connections	9
Connecting to a TV	9
Connecting to an Audio System	9
Connecting to Optional Equipment	10
Inserting batteries into the Remote Control	10
NTSC/PAL Conversion	11
Switching On	11
Menu Bars on TV Screen	11
Personal Preferences	12-14
Operation	
Basic Playback	15
Playing a DVD-Video	15
Playing a Video CD	16
Playing an Audio CD	16
Special DVD features	16-17
Special VCD & SVCD Features	17
General Features	17-20
Access Control	
Access Control: Child Lock	21
Access Control: Parental Control	21-22
Specifications	
Specifications	23
Maintenance	
Maintenance	23
Troubleshooting	
Troubleshooting	24

Laser safety

This unit employs a laser. Due to possible eye injury, only a qualified service person should remove the cover or attempt to service this device.

USE OF CONTROLS, ADJUSTMENTS OR PERFORMANCE OF PROCEDURES OTHER THAN THOSE SPECIFIED HEREIN MAY RESULT IN HAZARDOUS RADIATION EXPOSURE.

NOTE:
PICTURES SHOWN MAY BE DIFFERENT BETWEEN COUNTRIES.

LASER

Type	Semiconductor laser, GaAlAs
Wave length	650 nm (DVD) 780 nm (VCD/CD)
Output Power	7 mW (DVD) 10 mW (VCD/CD)
Beam divergence	60 degree

CAUTION
(WARNING LOCATION: ON THE BACKPLATE OF SET)
NEVER MAKE OR CHANGE CONNECTIONS WITH THE POWER SWITCHED ON.

General Information

The region code for this set is 2.

Since it is usual for DVD movies to be released at different times in different regions of the world, all players have region codes and discs can have an optional region code. If you load a disc of a different region code to your player, you will see the region code notice on the screen. The disc will not play, and should be unloaded.



Manufactured under license from Dolby Laboratories. "Dolby", "Pro Logic" and the double-D symbol are trademarks of Dolby Laboratories.

This product incorporates copyright protection technology that is protected by method claims of certain U.S. patents and other intellectual property rights owned by Macrovision Corporation and other rights owners. Use of this copyright protection technology must be authorised by Macrovision Corporation, and is intended for home and other limited viewing uses only unless otherwise authorised by Macrovision Corporation. Reverse engineering or disassembly is prohibited.

TruSurround and the  symbol are trademarks of SRS Labs, Inc. TruSurround technology is incorporated under license from SRS Labs, Inc.

 The DVD VIDEO player is in conformity with the EMC directive and low-voltage directive.

For Customer Use:

Read carefully the information located at the bottom of your DVD VIDEO player and enter below the Serial No. Retain this information for future reference.

Model No. DVD VIDEO _____
Serial No. _____

Introduction

Thank you for purchasing this Philips DVD player. This Owner's Manual explains the basic operation of this DVD player.

Environmental Information

All unnecessary packaging has been omitted. We have tried to make the packaging easy to separate into three materials: cardboard (box), polystyrene foam (buffer) and polyethylene (bags, protective foam sheet).

Your DVD player consists of materials which can be recycled and reused if disassembled by a specialised company. Please observe the local regulations regarding the disposal of packaging materials, exhausted batteries and old equipment.

Supplied accessories

- Remote control
- Batteries (two AA size) for remote control
- Audio cable
- SCART cable (not available for all versions)
- Owner's Manual



Safety Information

- Before operating the DVD player, check that the operating voltage indicated on the typeplate (or the voltage indication beside the voltage selector) is identical with the voltage of your local power supply. If not, please consult your dealer.
- Place the DVD player on a flat, hard and stable surface.
- There must be sufficient room in front of the player for the drawer to be opened.

- In cabinet, allow about 2,5cm (1 inch) of free space all around the player for adequate ventilation.
- Do not expose your player to extreme of temperature or humidity.
- If the DVD player is brought directly from a cold room, moisture may condense on the lens of the disc unit inside the DVD player. Should this occur, the DVD player would not operate normally. Leave the power on for about one hour with no disc in the DVD player until normal playback is possible.
- The mechanical parts of the set contain self-lubricating bearings and must not be oiled or lubricated.
- **When the DVD player is switched to Standby mode, it is still consuming some power. To disconnect the system from the power supply completely, remove the AC power plug from the wall socket.**

Symbols Used in this Manual

The below symbols appear in some headings and notes with the following meanings:

	– Description refers to playback of DVD-video discs
	– Description refers to playback of Video CDs
	– Description refers to playback of Audio CDs

Helpful Hints!

- Some DVD video discs require specific functions or allow only limited functions during playback.
- “X” may appears on the TV screen which means that the function is not available on that specific DVD video disc.

Functional Overview

Front and Rear Panels

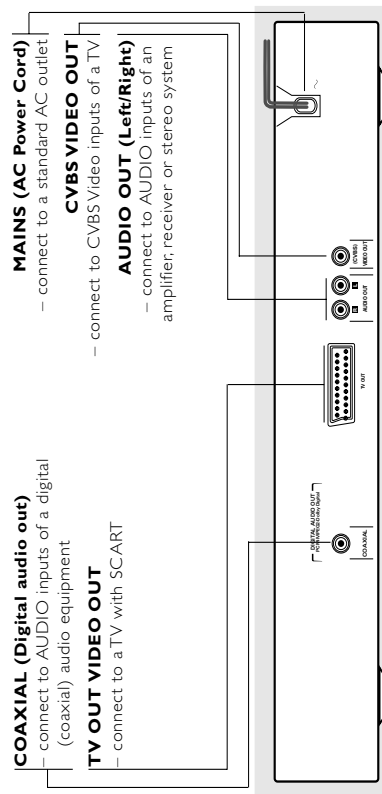
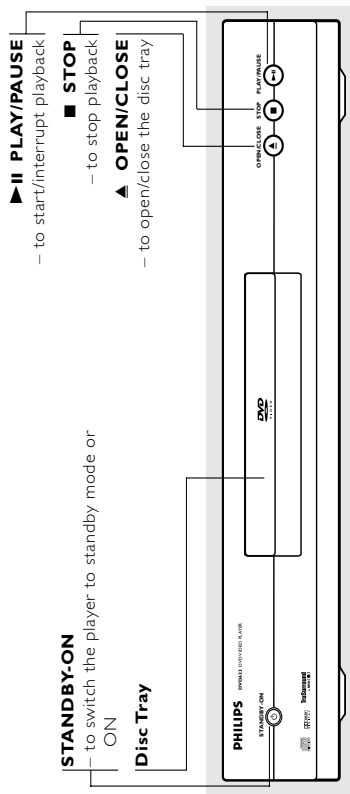

Caution: Do not touch the inner pins of the jacks on the rear panel. Electrostatic discharge may cause permanent damage to the unit.

Functional Overview

Remote Control

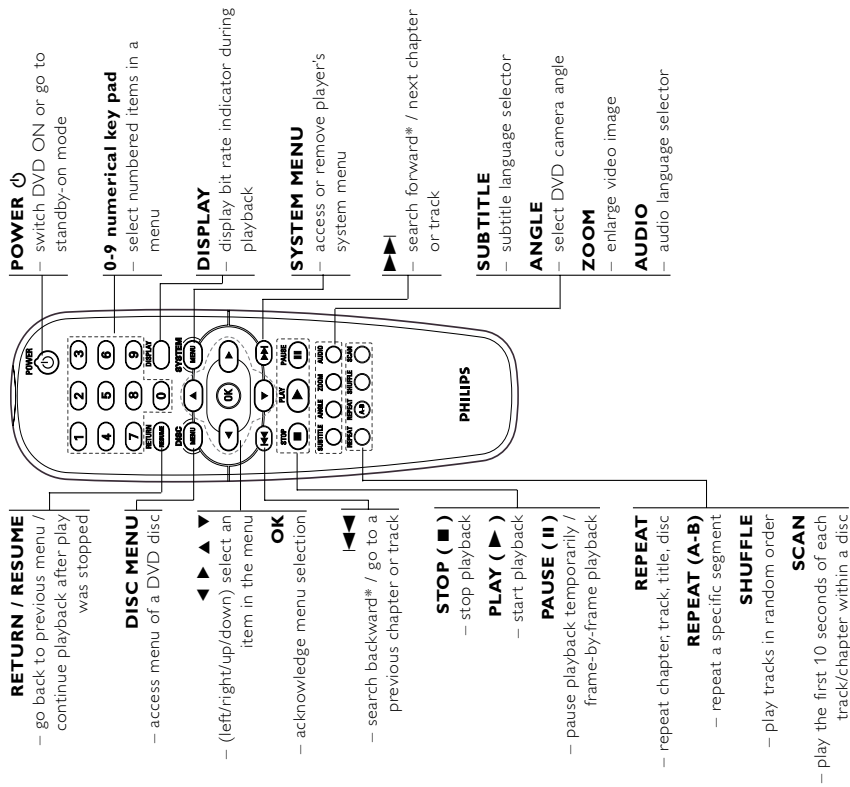
- 
- RETURN / RESUME**
- go back to previous menu / continue playback after play was stopped
- DISC MENU**
- access menu of a DVD disc
- POWER**
- switch DVD ON or go to standby-on mode
- 0-9 numerical key pad**
- select numbered items in a menu
- DISPLAY**
- display bit rate indicator during playback
- SYSTEM MENU**
- access or remove player's system menu
- SEARCH FORWARD* / next chapter or track**
- search forward* / next chapter or track
- SUBTITLE**
- subtitle language selector
- ANGLE**
- select DVD camera angle
- ZOOM**
- enlarge video image
- AUDIO**
- audio language selector
- RETURN / RESUME**
- go back to previous menu / continue playback after play was stopped
- DISC MENU**
- access menu of a DVD disc
- POWER**
- switch DVD ON or go to standby-on mode
- 0-9 numerical key pad**
- select numbered items in a menu
- DISPLAY**
- display bit rate indicator during playback
- SYSTEM MENU**
- access or remove player's system menu
- SEARCH FORWARD* / next chapter or track**
- search forward* / next chapter or track
- SUBTITLE**
- subtitle language selector
- ANGLE**
- select DVD camera angle
- ZOOM**
- enlarge video image
- AUDIO**
- audio language selector
- STOP (■)**
- stop playback
- PLAY (▶)**
- start playback
- PAUSE (||)**
- pause playback temporarily / frame-by-frame playback
- REPEAT**
- repeat chapter, track, title, disc
- REPEAT (A-B)**
- repeat a specific segment
- SHUFFLE**
- play tracks in random order
- SCAN**
- play the first 10 seconds of each track/chapter within a disc

* Press and hold key for about two seconds

8

Preparation

Basic Connections

- Please refer to the instruction books of your TV, VCR, Stereo System or other devices as necessary to make the best connections.
- Make one of the following connections, depending on the capabilities of your existing equipment.

The following guidelines are options for the best picture and sound quality available on your DVD player.

Picture

- 1 Use the CVBS Video Output for good picture quality.
- 2 Use SCART Output for best picture quality.

Sound

- 1 Digital audio connections provide the clearest sound. Connect one of the DVD player's DIGITAL AUDIO OUT (COAXIAL) to your amplifier or receiver.
- 2 If digital connections are not possible, connect the DVD player's red and white AUDIO OUT to your amplifier, receiver, stereo or TV.

Warning!

- Never make or change connections with the power switched on.
- Connect the DVD player directly to your TV, instead of eg. a VCR, to avoid distortion because DVD video discs are copy protected.
- Do not connect the DVD player AUDIO OUT to PHONO IN of your amplifier or receiver.

Connecting to a TV

- 1 Connect the SCART (TV OUT) to the corresponding connector on the TV IN.

Note:

- Ensure that the "TV" indication on SCART cable is connected to the TV set and "DVD" indication on SCART cable is connected to the DVD player.

If your TV is not equipped with a SCART input, you can select the following connection:

English

If your TV has a CVBS Video input connector,

- 1 Connect the CVBS VIDEO OUT on the DVD player to the CVBS VIDEO IN.
- 2 Connect the Left and Right AUDIO OUT on the DVD player to the Left and Right AUDIO IN on the TV.

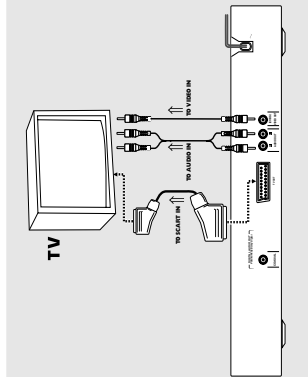

Connecting to an Audio System

- 1 You can also listen to the sound of audio CDs and DVD video discs by connecting to an optional stereo system.
- 2 Connect the Left and Right AUDIO OUT on the DVD player to the Left and Right AUDIO IN on the stereo system.

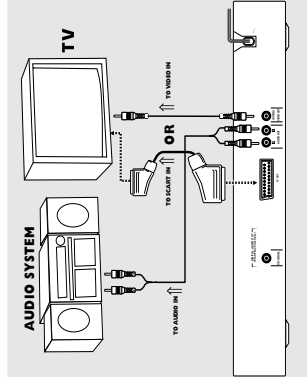

9

Preparation

English

Connecting to Optional Equipment

- A digital component with a built-in MPEG 2 or Dolby Digital™ decoder allows you to enjoy the surround sound while producing the effect of being in a movie theater or a concert hall.
 - The player outputs the surround sound signals from the DIGITAL OUT COAXIAL connectors.
- 1 **If your receiver has a MPEG 2 or Dolby Digital™ decoder,**
Connect the COAXIAL DIGITAL AUDIO OUT of the DVD player to the COAXIAL DIGITAL AUDIO IN on your receiver.
 - 2 You will need to set the DVD player's digital output to ALL (see 'Personal Preferences').

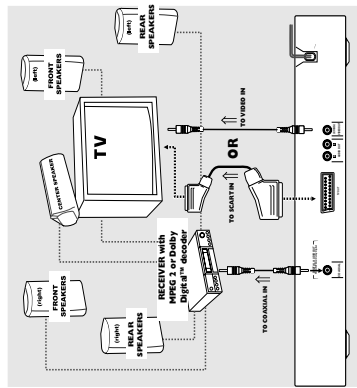

- Notes:**
- If the audio format of the digital output does not match the capabilities of your receiver, the receiver will produce a strong, distorted sound or no sound at all.
 - To see the selected audio format of the current DVD in the Status Window, press SYSTEM MENU.

Inserting batteries into the Remote Control

- 1 Open the battery cover.
- 2 Insert batteries (AA size) with the correct polarity as indicated by the + and - symbols inside the battery compartment.
- 3 Close the cover.

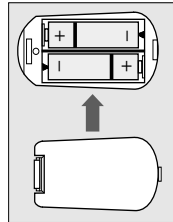

CAUTION!

- Remove batteries if they are exhausted or not to be used for a long time.
- Do not use old and new or different types of batteries in combination.
- Batteries contain chemical substances, so they should be disposed off properly and kept away from children.

Using the Remote Control

- Direct the remote control at the remote sensor of the DVD player.
- Do not drop the remote control.
- Do not leave the remote control near extremely hot or humid place.
- Do not spill water or put anything wet on the remote control.

Preparation

English

Menu bar 1



From the left,
Personal Preferences → Subtitle Language → Audio Language → Colour → Sound

Menu bar 2



From the left,
Step by step playback → Slow motion → Fast motion → Angle → Zoom

Menu bar 3



From the left,
Title → Chapter → Time Search → Favourite Track Selection (FTS)

NTSC/PAL Conversion

This player is equipped with an NTSC/PAL conversion feature that converts the video output of the disc to match your TV system. To activate the conversion refer to page 13.

Switching On

- 1 Switch on the TV and DVD player.
- 2 Set the TV to the correct Video IN channel (eg. EXT1, EXT2, AV1, AV2, AUDIO/VIDEO etc. (Refer to your TV owner's manual for detail) → The player display lights up and the default screen appears on the TV.
- 3 If you are using an external equipment (eg. audio system or receiver), turn them on and select the appropriate input source that was used to connect to the DVD player output. Refer to the equipment owner's manual for detail.

Menu Bars on TV Screen

- Operations can be carried out directly via the multiple menu bars on the TV screen.
- The following functions are available via the menu bars. Pressing SYSTEM MENU keys repeatedly will toggle through menu bar 1, menu bar 2, menu bar 3 and menu bar OFF:

Scan	h	Repeat A to end
Repeat All	h-B	Repeat A-B
Repeat Title	h	Angle
Repeat Track	h	Child Lock On
Repeat Chapter	h	Child Safe
Shuffle	h	Resume
Shuffle Repeat	h	Action Prohibited

Preparation

Personal Preferences

In the Personal Preferences settings menu, you can customize you player to suit your own particular requirements.

General operation:

- 1 Press SYSTEM MENU on the remote control.
- 2 The **▶** will be highlighted in the menu bar.
- 3 Press **▼** to activate the Personal Preferences menu.
- 4 Use the **◀ ▶ ▲ ▼** keys to toggle through the functions and select your preferred option.
- 5 Press OK to confirm a highlighted selection. The following items are available:

Picture

– TV Shape

Select the aspect ratio of the TV to be connected.

16:9 → when you connect a wide-screen TV to the DVD player.

4:3 LETTER BOX → when you connect a normal TV to the DVD player: Displays a wide picture with bands displayed on the upper and lower portions of the TV screen.

4:3 PAN SCAN → when you connect a normal TV to the DVD player: Displays the wide picture on the whole TV screen with a portion automatically cut off.

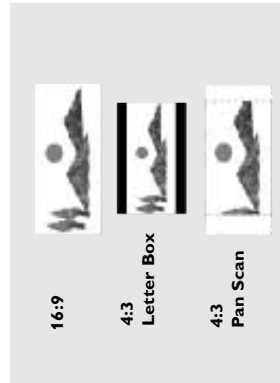

Note:

- Pan Scan is subject to availability on the disc.

– Black level shift (NTSC output only)

Select ON for adapting the colour dynamics to obtain richer contrasts.



– Video shift

Use this setting to personalize the position of the picture on your TV by scrolling it to the left or right.



– Smart Picture

• Colour settings

You can select one of five predefined sets of colour settings and one set (Personal) which you can define yourself.



- When **Personal** is selected it allows you to fine-tune saturation, brightness and contrast.
- Use **▲** or **▼** keys to adjust the values of these parameters.

Preparation

– Analogue output

Select Stereo, Dolby Surround-compatible or 3D Sound output to match your system's playback capability.



– TV System (NTSC/PAL Conversion)

Allows you to select between PAL, NTSC and AUTO mode depending on your TV. The conversions supported are as follows:

Disc	Type	Format	Output format		
			NTSC	PAL	AUTO
DVD		NTSC	NTSC	PAL	AUTO
		NTSC	NTSC	PAL	NTSC
		PAL	NTSC	PAL	PAL
VCD		NTSC	NTSC	PAL	NTSC
		PAL	NTSC	PAL	PAL

- 1 In the Personal Preferences Menu, select **TV System**.

- 2 Press **▲** or **▼** to select PAL, NTSC or AUTO.

Notes:

- **AUTO can only be selected when using a TV that has both the NTSC and PAL systems.**
- **This is applicable for CVBS output on cinch and SCART only.**
- **Slight picture distortions may occur due to this conversion. This is normal. Thus, the AUTO format is most suitable for the best picture quality.**

Sound

– Digital output

Digital output selection enables you to specify the type of digital output which is suitable to your receiver:

- Select **ALL** (default setting), if you had connected your DIGITAL AUDIO OUT to a multichannel decoder receiver.
- Select **PCM** only, if your receiver is not capable of decoding multichannel audio.
- Select **OFF** to deactivate the DIGITAL AUDIO OUT.



Preparation

Language

Selecting disc languages:

Menu/Audio/Subtitle language

- This is to select the audio language, subtitle language and the language used in TV screen menus or DVD menus which will always be used for every disc to be played back.
- If the language selected is not available on the disc, the original language designated by each disc will be selected.

Features

Access Control

Access Control contains the following features:
 Child Lock - When Child Lock is set to ON, a 4-digit code needs to be entered in order to playback discs.
 Parental control - Allows the conditional presentation of DVDs containing Parental Control information (see 'Access Control' section).

Status Window

Displays the current status of the player and appears with the menu bar. When disc playback is stopped, it is displayed with the 'Temporary Feedback Field' in the default screen. See 'On-Screen Display' information.
 Factory setting is ON. Select OFF to suppress display of the Status Window.



Basic Playback

- Press **STANDBY ON** on the front panel.
- Press **OPEN/CLOSE** ▲ on the front panel to open disc loading tray.
- Place the chosen disc in the tray, with the label facing up.
- Press **OPEN/CLOSE** ▲ again to close the tray. → **REPLAYING** appears in the status window and on the player display, and playback starts automatically.

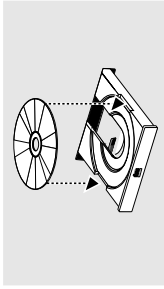

Notes:

- DVDs may have a region code. Your player will not play discs that have a region code different from the region code of your player.
- If 'Child Lock' is set to ON and the disc inserted is not authorised, the 4-digit code must be entered and/or the disc must be authorised (see 'Access Control').

Operation

Playing a DVD-Video

- DVD video discs may have one or more **TITLES**, and each **TITLE** may have one or more **CHAPTERS**.
- Playback stops at the end of each **TITLE**.

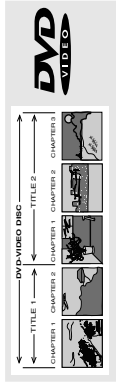

Playing a title

- Insert a disc and close the tray, playback starts automatically.
 - The TV screen's and DVD player's display shows the type of disc loaded, disc's information and playing time.
- When the **Disc Menu** appear on the TV screen, use **◀▶** keys or numerical keys on the remote control to select an option and continue playback.
 - If the titles are numbered, press the numerical keys or use the **▶** keys to select desired title in the menu bar.
- To stop playback, press **STOP**.

Smart Resume

- In stop mode and when a disc has not been ejected.
 - Pressing **PLAY** will automatically resume playback from the point where the playback was last stopped.

To deactivate auto resume,

- Press **STOP** to stop playback.
 - The help line text appears "Press Stop again to start from beginning" for 5 seconds.
- Press **STOP** again or unload the discs, the auto resume is cancelled.

To activate auto resume,

- Reload the disc and press **PLAY**.
 - Playback starts from the beginning of the title, press **PLAY** again.
- When resume icon ▶ appears on the screen,
 - Playback will resume from the point where the playback was last stopped.

Note:

- Resume feature is also applicable to VCDs and SVCDs.

Operation

Playing a Video CD

- Video CDs may have one or more TRACKS, and TRACKS may have one or more INDEXES.
- To make easy and convenient access, you can move between TRACKS and INDEXES.
- Some Video CDs have Play Back Control (PBC), which is a predefined playback sequence stored on the disc (see *Playback Control* section).

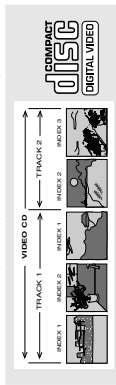

Playing a disc

- 1 Insert a disc and close the tray, playback starts automatically.
 - The number of tracks and the total playing time of the disc will appear on the TV screen and DVD player's display.
- 2 Press **PLAY**.
 - The current track number and its elapsed playing time will be displayed.
- 3 Playback will stop at the end of the disc.
- 4 To stop playback, press **STOP**.
- 5 Disc Resume feature is also applicable for VCDs and SVCDs (see 5 Disc Resume section).

Playing an Audio CD

- Audio CDs contain only TRACKS.
- They can be played on your DVD player with the audio output connected to a stereo system or to your TV.
- Select tracks using the menubar on the TV screen or by pressing the numerical keys directly.
- Your DVD player also allows you to compile Favourite Track Selection (FTS) programmes for your discs by selecting or excluding tracks of your choice (see FTS Programme - Audio CDs).

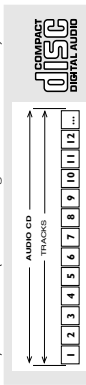

Playing a disc

- 1 Insert a disc and close the tray, playback starts automatically.
 - The menu bar on TV screen will display the number of tracks for selection. Playback will stop at the end of the disc.
- 2 To stop playback, press **STOP**.

Special DVD Features

DVDs may contain menus to navigate the disc and access special features. Press the appropriate numerical key or use the **▲**, **▶**, **▼**, **◀** keys to highlight your selection in the DVD menu and press **OK** to confirm.

Title/Disc menu

- 1 Press **DISC MENU**.
 - If the current title has a menu, the menu will appear on the screen. Otherwise, the disc menu will be displayed.
- 2 If disc menu is available on the disc, audio language, subtitle options, chapters for the title and other options will appear for selection.
- 3 To remove the title/disc menu, press **DISC MENU** again.

Camera Angle

Some discs contain scenes which have been shot simultaneously from various angles. This DVD player allows you to select the desired camera angle.

- When the DVD player encounters a scene shot in multiple angles, it will give you an indication on the "Temporary Feedback Field."
- The angle icon remains displayed until multiple angles are no longer available.
- Use the **▲** to select the required angle icon.
- Playback changes to the selected angle. You can also select **ANGLE** in the menu bar or press the **ANGLE** button on the remote control directly.

Operation

General Features

Note:

- Unless stated, all operations described are based on remote control use. Some operations can be carried out using the menu bar on the TV screen.

Moving to another title/chapter

DVD XCD

When a disc has more than one title/track or chapter, you can move to another title/chapter as follows:

- 1 Press **SYSTEM MENU**, then select **T** or **C** in the menu bar.
- 2 Press **▲** or numerical keys to select a title/chapter.

CD

- 1 Press **▶▶** or **◀◀** briefly during playback to go to the next track or to return to the beginning of the current track respectively.
- 2 Press **◀◀** twice briefly to step back to the previous track.
- 3 To go directly to any track, enter the track number using the numerical keys (0-9).

Note:

- Long press of the **▶▶** or **◀◀** keys will switch the DVD player on **BACKWARD** or **FORWARD** search (see **SEARCH** section).

Search

DVD XCD

- 1 Select **SEARCH** (FAST MOTION) in the menu bar and press **▶**.
- 2 Use the **◀** keys to select the required speed: -32, -8 or -4 (backward), or +4, +8, +32 (forward).
- 3 Select 1 to play the disc at normal speed again.
- 4 To exit FAST MOTION mode, press **PLAY** or **▶**.

CD

- To search forward or backward through different speeds, you can also hold down **▶▶** or **◀◀** respectively.

Operation

English

- 1 Slow Motion**
- Select (SLOW MOTION) in the menu bar and press **▼**.
- Playback will pause.
- 2** Use the cursor keys **◀▶** to select the required speed: -1, -1/2, -1/4 or -1/8 (backward), or +1/8, +1/4, +1/2 or +1 (forward).
- 3** Select 1 to play the disc at normal speed again.
- 4** If is pressed, the speed will be set to zero (PAUSE).
- 5** To exit slow motion mode, press **PLAY**.

Still Picture and Frame-by-frame playback

- 1** Select (STEP) in the menu bar and press **▼**.
- Playback will pause.
- 2** Use the cursor keys **◀▶** to select the previous or next picture frame.
- 3** To exit step by step playback, press **PLAY** or **▲**.

Note:

- You can also activate *frame-by-frame playback* by pressing the **PAUSE** key repeatedly on the remote control.

Scan

Scanning plays the first 10 seconds of each chapter/track on the disc.

- 1** Press **SCAN**.
- 2** To continue playback at your chosen chapter/track, press **SCAN** again or press **PLAY**.

- Repeat**
- Repeat chapter/title/disc**
- To repeat the current chapter, press **REPEAT**.
 - → **RPT CHP** appears on the front display.
- 1** To repeat the current title, press **REPEAT** a second time.
- → **RPT TTL** appears on the front display.
- 2** To repeat the entire disc, press **REPEAT** a third time.
- → **RPT ALL** appears on the front display.
- 3** To exit Repeat mode, press **REPEAT** a fourth time.

Repeat track/disc

- To repeat the current track, press **REPEAT**.
 - → **RPT TRK** appears on the front display.
- 1** To repeat the entire disc, press **REPEAT** a second time.
- → **RPT ALL** appears on the front display.
- 2** To exit Repeat mode, press **REPEAT** a third time.

Repeat A-B

- **DVD-Video Discs: repeat a sequence in a title**
- **Video and Audio CDs: repeat a sequence in a track**

- 1** Press **REPEAT** A-B at your chosen starting point.
- 2** Press **REPEAT** A-B again at your chosen end point.
- **RPT A-B** appears briefly on the front display, and the repeat sequence begins.
- 3** To exit the sequence, press **REPEAT** A-B.

Shuffle

This shuffles the playing order of chapters within a title, if the title has more than one chapter.

- 1** Press **SHUFFLE** during playback.
- **SHUFFLE** appears on the screen for about two seconds.
- 2** To return to normal playback, press **SHUFFLE** again.

XCD

This shuffles the playing order of tracks within a disc, if the disc has more than one tracks.

- 1** Press **SHUFFLE** during playback.
- **SHUFFLE** appears on the screen for about two seconds.
- 2** To return to normal playback, press **SHUFFLE** again.

Time search

The Time Search function allows you to start playing at any chosen time on the disc.

- 1** Select (TIME SEARCH) in the menu bar and press **▼**.
- Playback will pause.
 - The elapsed playing time is displayed in a time edit box.
- 2** Enter hours, minutes and seconds from left to right in the time edit box using remote control numerical key pad.
- Each time an item has been entered, the next item will be highlighted.
- 3** Press **OK** to confirm the selected time.
- The time edit box will disappear and playback starts from the selected time position on the disc.



- 4** Press **SYSTEM MENU** to remove the menu bar.

Operation

English

Zoom

The Zoom function allows you to enlarge the video image and to pan through the enlarged image.

- 1** Select (ZOOM).
- 2** Press **▲▼** to activate the **ZOOM** function and select the required zoom factor: 1.33 or 2 or 4.
- Playback will continue.
 - The selected zoom factor and 'Press OK to pan' appears below the menu bar.
 - The zoomed picture will appear on the TV screen.
- 3** Press **OK** to confirm the selection.
- The panning icon appears on the screen.
- 4** Use the **◀▶** keys to pan across the screen.
- 5** When **OK** is pressed only the panned picture will be shown on the screen.
- 6** To exit **ZOOM** mode, select zoom factor to "Off" (zoom factor 1) in the menu bar.



FTS Video/Audio Programme

- Favourite Track Selection (FTS) list contains 20 items (titles, chapters).
- The most recent programme list will be placed on top of the existing list.

DVD

Storing a Programme

- 1** While playback is stopped, select **VIDEO FTS** in the menu bar.
- 2** Press **▼** to open the menu bar.
- The **VIDEO FTS** menu appears.
- 3** Press **▶** or **◀** or **FTS** (on the remote control) to select **ON**.

Operation

English

Storing titles/tracks

- 1 Press **▼** to select **TITLES/TRACKS**.
- 2 Use **▶** and **◀** to select the require title/tracks.
- 3 Press **OK** to store the entire selected title/tracks.
→ The title number will be added to the list of selections.

Storing chapters/indexes

- 1 Press **▼** on the selected chapter/indexes number:
→ The chapter/indexes number will be highlighted.
- 2 Use **▶** and **◀** to select the required chapter number.
- 3 Press **OK** to confirm the selection.
→ The selected chapter/indexes confirmation will be added to the list of selections.
- 4 Press **SYSTEM MENU** to exit the **VIDEO FTS** menu.

Erasing a selection in a Programme

- 1 While playback is stopped, select **VIDEO FTS** in the menu bar.
- 2 Use **▼** to select **PROGRAM**.
- 3 Use **▶** and **◀** to select the required number.
- 4 Press **OK** to erase the selection.
- 5 Press **SYSTEM MENU** to exit.

Erasing all selections

- 1 While playback is stopped, select **VIDEO FTS** in the menu bar.
- 2 Use **▼** to select **CLEAR ALL** and press **OK**.
→ All selections will be erased.
- 3 Press **SYSTEM MENU** to exit.



Storing a Programme

- 1 Load a disc and stop playback.
- 2 Press **▼** to go to the list of available tracks.
- 3 Use **▶** and **◀** to select the required tracks or directly using remote control numeric key.
- 4 Press **OK** to store the selected tracks.
→ The track number will be added to the list of selections.

Switching a Programme ON/OFF

- 1 Use **▲▼** to move and select desired tracks.
- 2 Press **▶** or **◀** to select either **ON** or **OFF**.

Erasing a track in a Programme

- 1 Use **▼** to go to the programmed tracks.
- 2 Use **▶** and **◀** to select the required number.
- 3 Press **OK** to erase the selection.
- 4 Press **SYSTEM MENU** to exit.

Erasing all selections

- Use **▼** to select **CLEAR ALL** and press **OK**.
→ All selections will be erased.



Access Control

English

- Each time a 'child safe' disc is played, it will be placed on top of the list. When the list is full, the last disc in the list will be replaced when a new disc is added.
- Double-sided DVDs and multi-volume VCDs may have a different ID for each side. In order to make the disc 'child safe', each side has to be authorised.



Child Lock DVD XCD

Activating/deactivating the Child Lock

- 1 When disc playback is stopped, select **ACCESS CONTROL** in the Personal Preferences menu using the **▲▼** keys.
- 2 Enter a 4-digit code of your own choice twice.
- 3 Move to **'CHILD LOCK'** using the **▲▼** keys.
- 4 Move to **ON/OFF** using the **▶** keys.
- 5 Select **ON** using the **▲▼** keys.
- 6 Press **OK** or **◀** to confirm, then press **◀** again to exit the Personal Preferences menu.
→ Now unauthorised discs will not be played unless the 4-digit code is entered.
- 7 Select **OFF** to deactivate the **CHILD LOCK**.

Notes:

- Confirmation of the 4-digit code is necessary when:
- The code is entered for the very first time (see above),
- The code is changed or cancelled (see 'Changing the 4-digit code').



Deauthorising discs

- 1 Insert the disc.
→ Playback starts automatically.
- 2 Press **■** while **☺** is visible.
→ The **☺** will appear and the disc is now deauthorised.

Parental Control DVD

Movies on DVDs may contain scenes not suitable for children. Therefore, discs may contain 'Parental Control' information which applies to the complete disc or to certain scenes on the disc. These scenes are rated from 1 to 8, and alternative, more suitable scenes are available on the disc. Ratings are country dependent. The 'Parental Control' feature allows you to prevent discs from being played by your children or to have certain discs played with alternative scenes.



Authorising discs

- 1 Insert the disc.
→ The 'child safe' dialog will appear.
- 2 You will be asked to enter your secret code for 'Play Once' or 'Play Always'.
- If 'Play Once' disc can be played when in the player and the player is ON.
- If 'Play Always' disc will become authorised and can always be played, even if the Child Lock is set to ON.

Notes:

- The player memory can maintain 120 authorised ('Child safe') disc titles. A disc will be placed in the list when 'Play Always' is selected.

Troubleshooting

English

WARNING
Under no circumstances should you try to repair the system yourself, as this will invalidate the warranty. Do not open the system as there is a risk of electric shock.

If a fault occurs, first check the points listed below before taking the system for repair. If you are unable to remedy a problem by following these hints, consult your dealer or service centre.

Problem	Solution
No power	<ul style="list-style-type: none"> Check if the AC power cord is properly connected. Press Standby-On key on the DVD player.
No picture	<ul style="list-style-type: none"> Check if the TV is switched on. Check the video connection.
Distorted picture	<ul style="list-style-type: none"> Sometimes a small amount of picture distortion may appear. This is not a malfunction.
Completely distorted picture or black/white picture with DVD or-Video CD	<ul style="list-style-type: none"> Make sure the NTSC/PAL setting at the DVD player matches the video signal of your television. (See NTSC/PAL Conversion/Settings)
No sound or distorted sound	<ul style="list-style-type: none"> Adjust the volume. Check that the speakers are connected correctly. Select another audio language (if available on the DVD video disc)
No audio at digital output	<ul style="list-style-type: none"> Check the digital connections. Check the settings menu to make sure the digital output is set to ALL or PCM.
No sound and picture	<ul style="list-style-type: none"> Check if the audio format of the selected audio language matches your receiver capabilities.
Disc can't be played	<ul style="list-style-type: none"> Check that the SCART cable is connected to the correct device (See Connecting to a TV) Ensure the disc label is facing up. Check if the disc is defective by trying another disc.
No return to start-up screen when disc is removed	<ul style="list-style-type: none"> Reset the unit by switching the player off then on again.
The player does not respond to the remote control	<ul style="list-style-type: none"> Aim the remote control directly at the sensor on the front of the player. Reduce the distance to the player. Replace the batteries in the remote control. Re-insert the batteries with their polarities (+/- signs) as indicated.
Buttons do not work or player stops responding	<ul style="list-style-type: none"> To completely reset the player, unplug the AC cord from the AC outlet for 5-10 seconds.
Player does not respond to some operating commands during playback.	<ul style="list-style-type: none"> Operations may not be permitted by the disc. Refer to the instructions of the disc.
DVD Video player cannot read CDs/DVDs	<ul style="list-style-type: none"> Use a commonly available cleaning CD/DVD to clean the lens before sending the DVD Video player for repair.

Access Control

English

Activating/Deactivating Parental Control

- When disc playback is stopped, select **ACCESS CONTROL** in the Personal Preferences menu using the **▲▼** keys.
- Enter your 4-digit code. If necessary, enter the code a second time.
- Move to **Parental Control** using the **▲▼** keys.
- Move to value adjustment (1-8) using the **▶** key.
- Then use the **▲▼** keys or the numerical keys on the remote control to select a rating from 1 to 8 for the disc inserted.

Rating 0 (displayed as -):
Parental Control is not activated. The Disc will be played in full.

Ratings 1 to 8:
The disc contains scenes not suitable for children. If you set a rating for the player, all scenes with the same rating or lower will be played. Higher rated scenes will not be played unless an alternative which has the same rating or lower is available on the disc. If no suitable alternative is found, playback will stop and the 4-digit code has to be entered.

Parental Control Disclaimer

This DVD player features the **PARENTAL CONTROL** system which is to activate when playing DVD discs furnished with certain software coding only.

Also note that at the time of release of this DVD player, certain aspects of the technical standards had not been settled between set makers and the disc industries.

On this basis, Philips cannot guarantee the functioning of the **PARENTAL CONTROL** system and denies any liability associated with unintended watching of disc content.

If in doubt, please make sure the disc plays according to your **PARENTAL CONTROL** settings before you allow children access to the player.



- When disc playback is stopped, select **ACCESS CONTROL** in the Personal Preferences menu using the **▲▼** keys.
- Enter the 4-digit code.
- Move to **CHANGE COUNTRY** using the **▼** key.
- Press the **▶** key.
- Select a country using **▲▼**.
- Press OK or **◀** to confirm, then press **◀** again to exit the menu.

4. Mechanical- and Dismantling Instructions

Dismantling Instructions

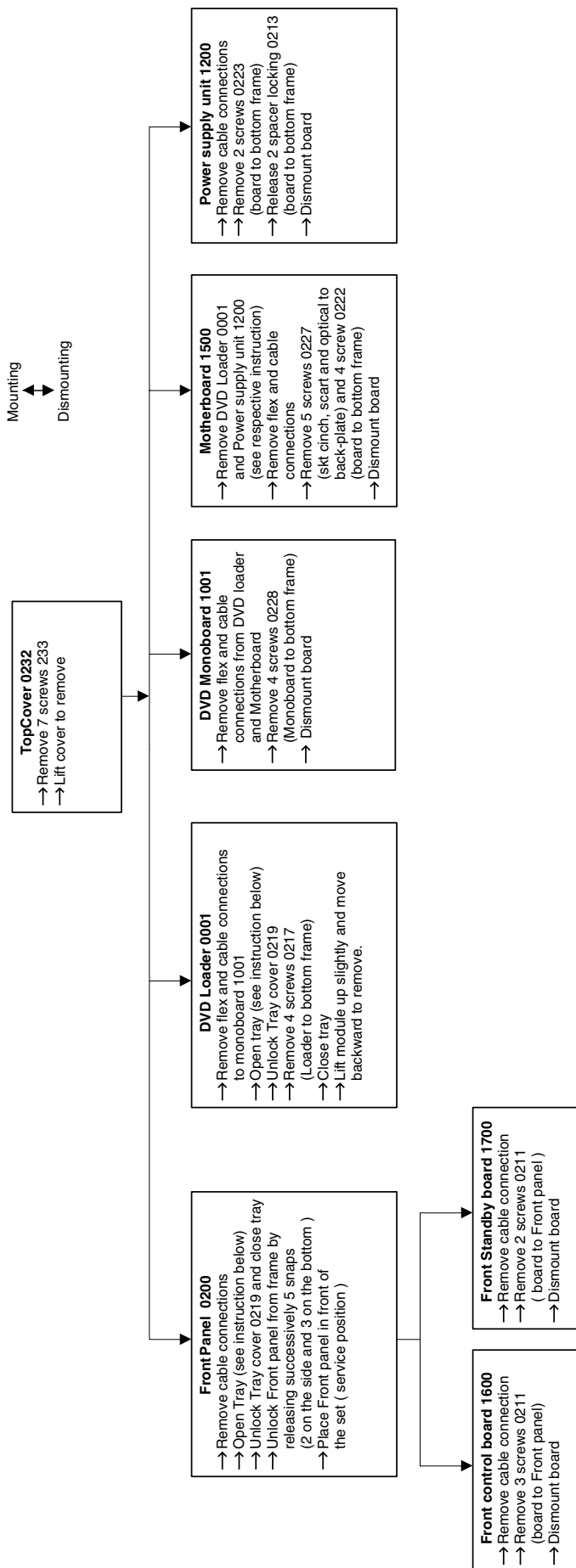

DISMANTLING INSTRUCTIONS
See exploded view for item numbers

Manually opening of tray

When it is not possible to open the tray with the EJECT button, the tray can manually be opened.
When no disc is loaded, unlock the tray by moving the slide from left to right and pull tray outwards.

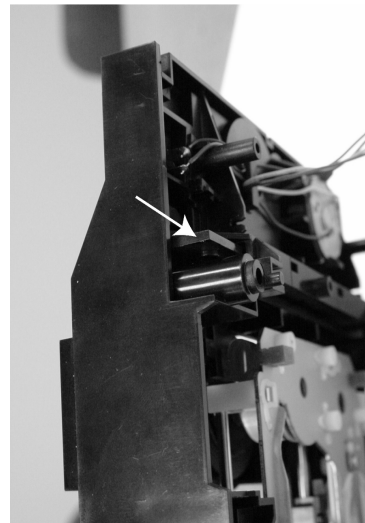
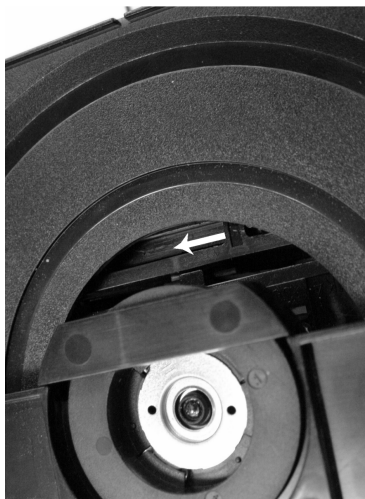

When a disc is loaded, unlock the tray by pushing the slide inwards with a screwdriver and pull tray outwards.

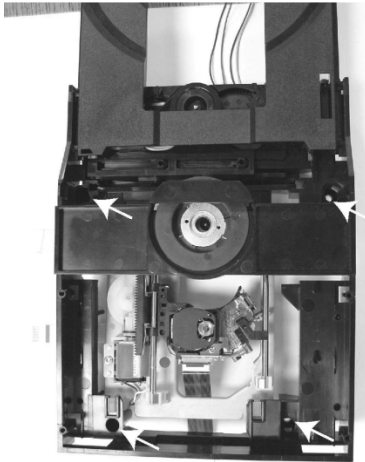

Remove 4 screws to remove loader.

Exploded View

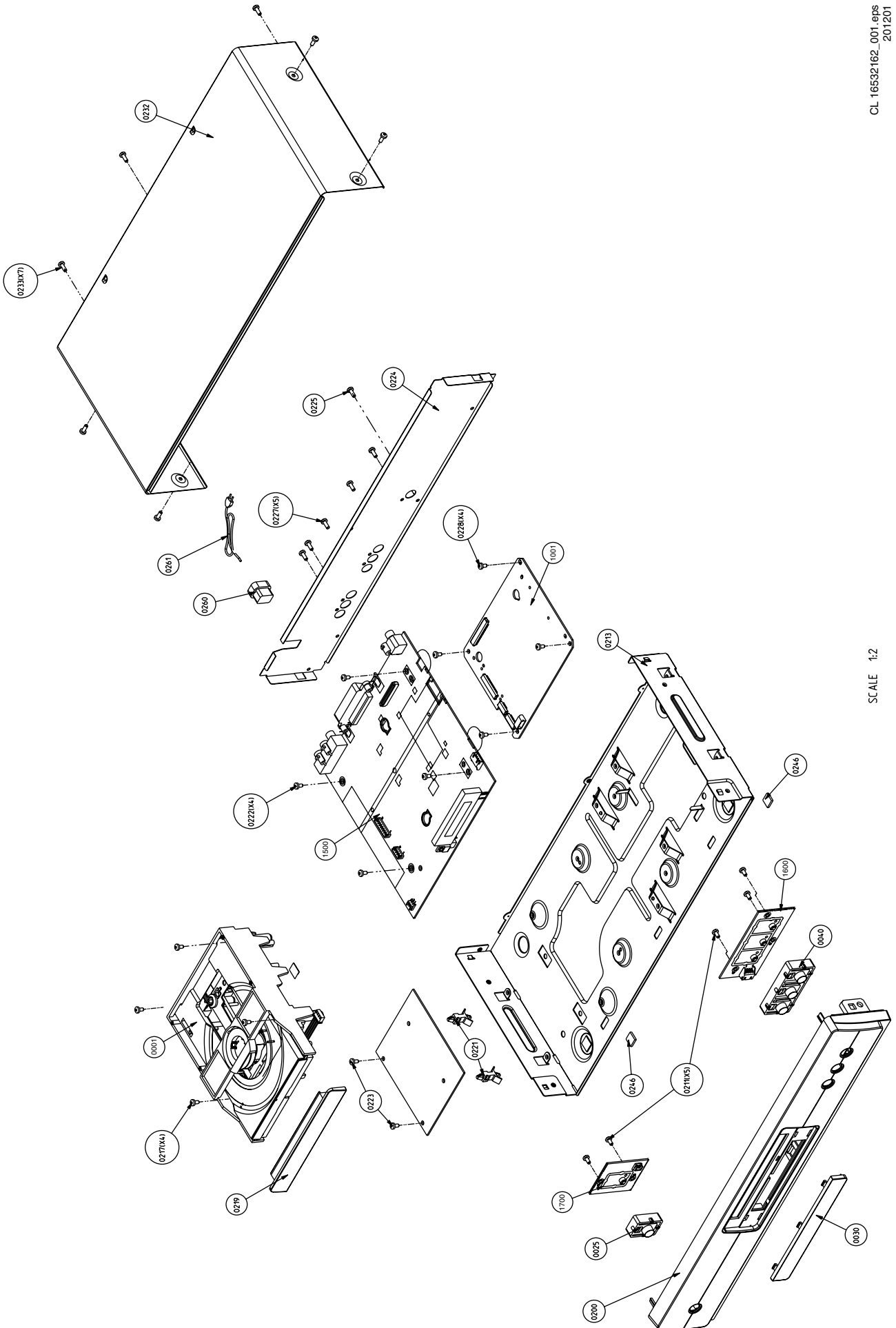

5. Diagnostic Software Descriptions and Troubleshooting

5.1 Dealerscript

5.1.2 Contents of Dealer Script

5.1.1 Purpose of Dealer Script

The dealer script can give a diagnosis on a standalone DVD player, no other equipment is needed to perform a number of hardware tests to check if the DVD player is faulty. The diagnosis is simply a "error" or "pass" message. No indication is given of faulty hardware modules. Only tests within the scope of the diagnostic software will be executed hence only faults within this scope can be detected.

The dealer script executes all diagnostic nuclei that do not need any user interaction and are meaningful on a standalone DVD player.

The nuclei called in the dealer script are the following (the number after each nucleus name corresponds with the number being on the local display when the nucleus is executed during the dealer script):

Nucleus

Display Countdown	Nucleus Number	Nucleus Name	Description
6	6	PapChksFl	Calculate and verify checksum of FLASH memory
5	12	PapI2cDisp	Checks the I2C interface with the slave processor on the display board
4	13	PapS2bEcho	Checks the I2C interface to the basic engine
3	11	PapI2cNvram	Checks the I2C interface with the NVRAM
2	15	PapNvramWrR	Pattern test of all locations in the NVRAM
1	16	CompSdramWrR	Pattern test of all locations in the SDRAM(s)

CL 16532162_026.eps
080102

Figure 5-1

Dealer Script

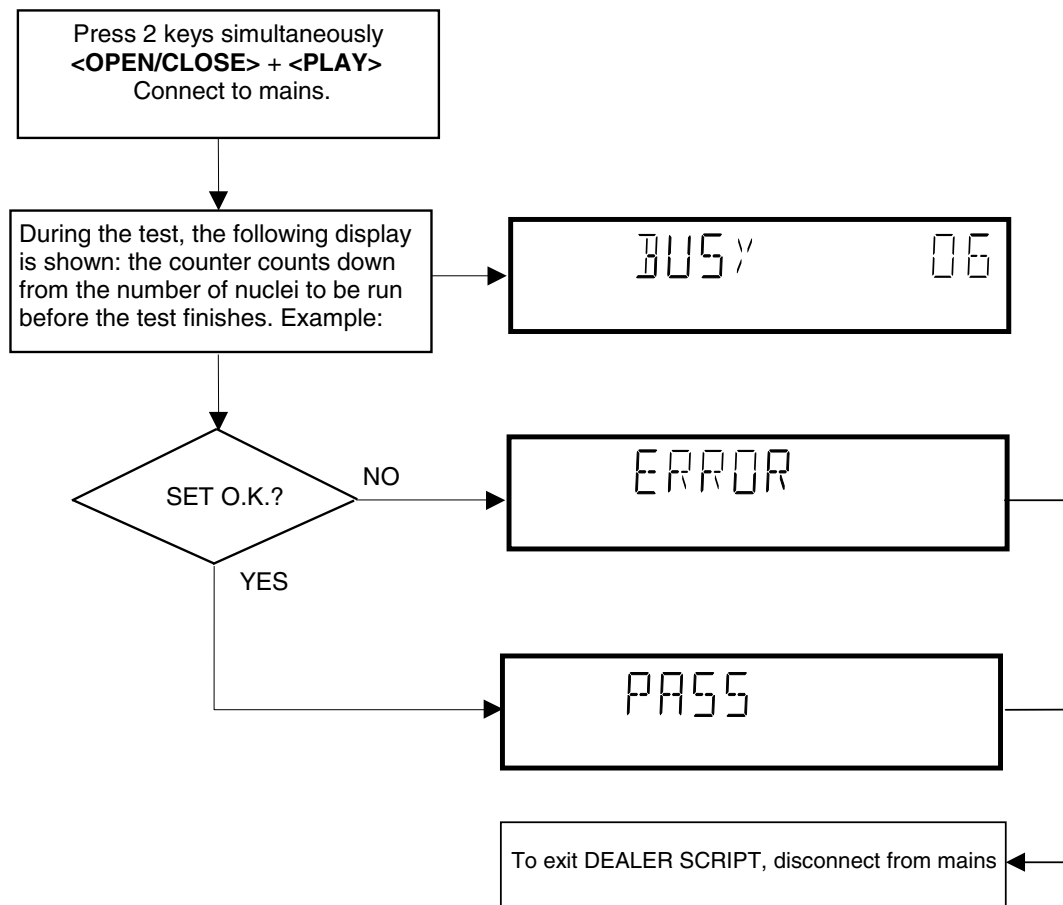

CL 16532162_027.eps
090102

Figure 5-2

5.2 Player Script

Press the OPEN/CLOSE key to proceed to the next test.

5.2.1 Purpose of Player Script

The Player script will give the opportunity to perform a test that will determine which of the DVD player's modules are faulty, to read the error log and error bits and to perform an endurance loop test. To successfully perform the tests, the DVD player must be connected to a TV set to check the output of a number of nuclei. For DVDv2b a multi-channel amplifier, a set of 6 speakers and an external video source are necessary to test. To be able to check results of certain nuclei, the player script expects some interaction of the user (i.e. to approve a test picture or a test sound). Some nuclei (e.g. nuclei that test functionality of the Basic Engine module) require that the DVD player itself is opened, to enable the user to observe moving parts and approve their movement visually. Only tests within the scope of the diagnostic software will be executed hence only faults within this scope can be detected.

5.2.2 Contents of Player Script

The player script contains all nuclei that are useful on a DVD player that is connected to a TV set and help to determine which module of the DVD player is faulty, as well as to read out the contents of the error logs.

5.2.3 Structure of Player Script

The player script consists of a set of nuclei testing the three hardware modules in the DVD player: the Display PWB, the Digital PWB, and the Basic Engine.

Nuclei run by the player test need some user interaction. In the next paragraph this interaction is described. The player test is done in two phases:

1. **Interactive tests:** this part of the player test depends strongly on user interaction and input to determine nucleus results and to progress through the full test. Reading the error log and error bits information can be useful to determine any errors that occurred recently during normal operation of the DVD player.
2. **The loop test:** this part of the player test will loop through the list of nuclei indefinitely, till the player is reset. The list of nuclei is as follows:
 - PapChksFlash
 - Papl2cNvram
 - CompSdramWrR
 - PapS2bEcho
 - Papl2cDisp

At the beginning of the tests, the DSW version number will be indicated on the local display of the DVD. The display will look like the following:

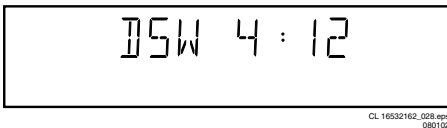

Figure 5-3

Pressing the PLAY key will proceed to the slave S/W version display, which is shown on the local display of the DVD player. The display will look like the following:

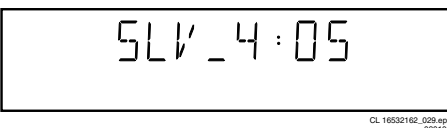

Figure 5-4

5.2.4 Survey

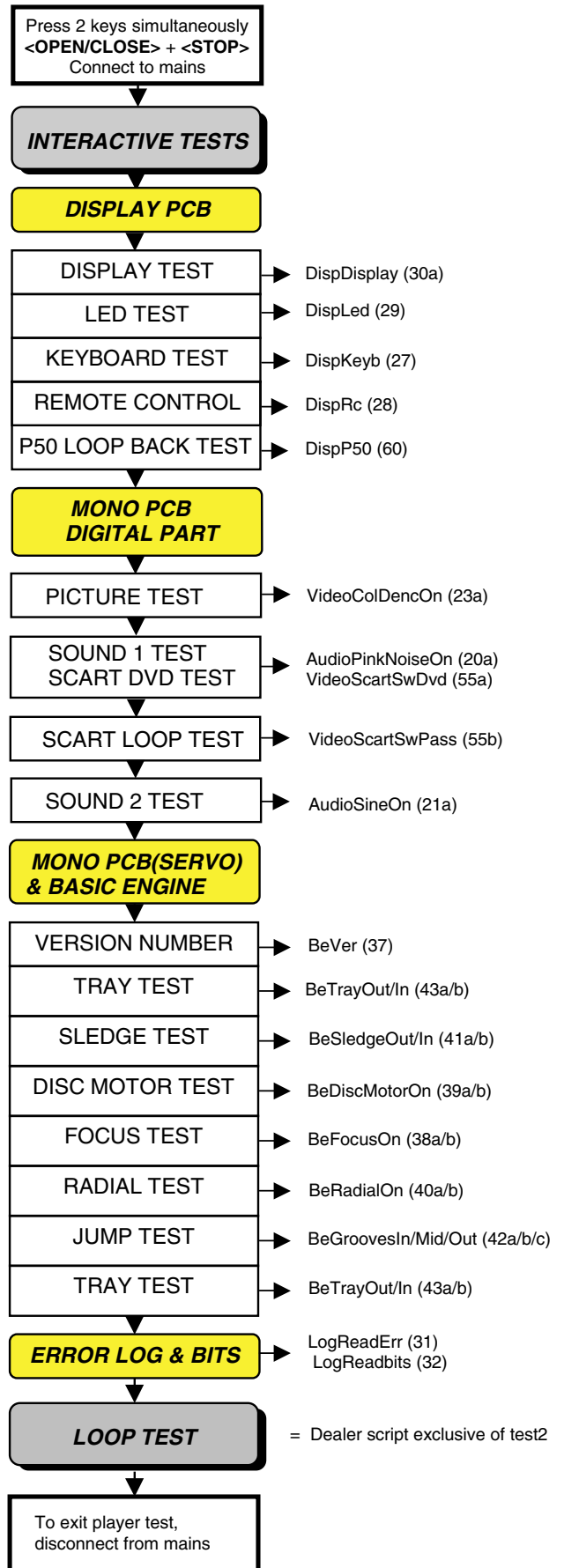

Figure 5-5

5.3 Display PCB

5.3.1 Display Test

The display test is performed by nucleus DispDisplay. By putting a series of test patterns on the local display, the local display is tested. To step through all different patterns, the user must either press OPEN/CLOSE (pattern is ok) or STOP (pattern was incorrect) to proceed to the next pattern. The display of patterns is continued in a cyclic manner, shown in Fig. 5-6, until the user presses PLAY. If the user presses PLAY before all display patterns are tested, the DispDisplay nucleus will return FALSE (display test unsuccessful).

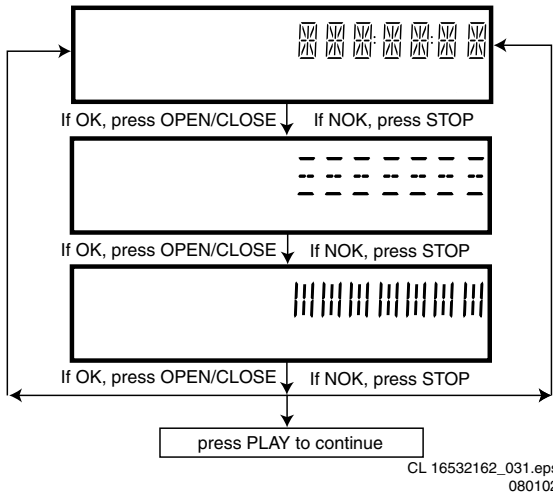

Figure 5-6

5.3.2 LED Test

The LED(s) on the DVD player is (are) tested by nucleus DispLed. The user must check if the LED(s) is (are) lighted; if it is, press OPEN/CLOSE, if it is not, press STOP. By pressing PLAY the script will proceed to the next test. If the user presses PLAY before OPEN/CLOSE or STOP, the DispLed nucleus will return TRUE (LED test successful).

5.3.3 Keyboard Test

The keyboard of the DVD player is tested by nucleus DispKeyb. The user is expected to press all keys on the local keyboard once. The code of the key pressed is shown on the local display (1 hexadecimal digit) immediately followed by a (hexadecimal) number indicating how many times that key has been pressed. Example of the local display during this test:

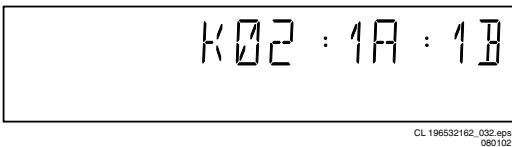

Figure 5-7

The key-codes displayed on the local display will scroll from right to left when the display gets full, the text "K" will remain on display.

Key ID	Key
0	PLAY
1	STOP
2	OPEN / CLOSE
3	STANDBY

CL 16532162_036.eps
080102

Figure 5-8

If any keys are detected more than once (due to hardware error), the key-code is displayed twice (or more), with the second digit increased by 1. If the user does not press all keys minimally once (in any order), the DispKeys nucleus will return FALSE and cause an error in the overall result of the player script. The user can leave the keyboard test by pressing the PLAY key on the local display of the DVD player for at least one full second. The result of the keyboard test is shown on local display as follows:

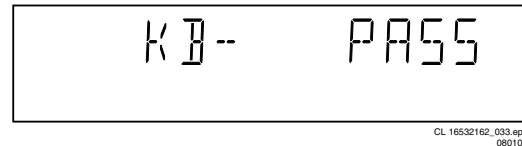

CL 16532162_033.eps
080102

Figure 5-9

Or

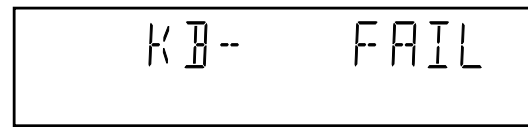

CL 16532162_034.eps
080102

Figure 5-10

Pressing PLAY on the local keyboard again will proceed to the next text.

5.3.4 Remote Control Test

The remote control of the DVD player is tested by nucleus DispRc. The user must press any key on the remote control just once. The codes of the key pressed will be shown on the local display in hexadecimal format. Example:

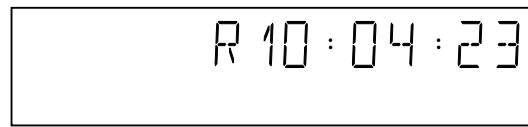

CL 16532162_035.eps
140102

Figure 5-11

In this example 23 is the hexadecimal code of the pressed RC key. The user can leave the remote-control test by pressing PLAY on the local keyboard of the DVD player. The remote control test is successful if a code was received before the user pressed the PLAY key. Pressing the PLAY key, before pressing a key on the remote control, gives an error in the remote control test (note that the remote control test will also fail if a key on the remote control was pressed but no code was received). The remote control test does not check upon the contents of the received code, that is it will not be checked if the received code matches the key pressed. If desired, the user

can manually check this code by using a code-table for the remote control key-codes.

RC Key id	Hexadecimal code
STANDBY	0C
1	1
2	2
3	3
4	4
5	5
6	6
7	7
8	8
9	9
0	0
RETURN	83
DISPLAY	EF
DISC MENU	54
SYSTEM MENU	82
CURSOR UP	58
CURSOR DOWN	59
CURSOR LEFT	5A
CURSOR RIGHT	5B
OK	5C
PREVIOUS	21
NEXT	20
STOP	31
PLAY	2C
PAUSE	30
SUBTITLE	4B
ANGLE	85
ZOOM	F7
AUDIO	4E
REPEAT	1D
REPEAT A-B	3B
SHUFFLE	1C
SCAN	2A

CL 16532162_037.eps
080102

Figure 5-12

After pressing PLAY, the result of the remote control test is displayed on the local display of the DVD player as follows:

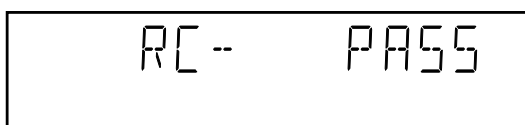

Figure 5-13

Or

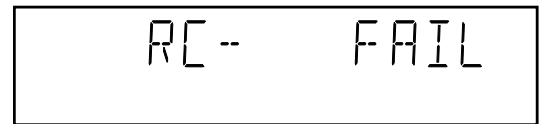

Figure 5-14

Pressing PLAY on the local keyboard again will proceed to the next test.

5.3.5 P50 Loop-Back Test

For the P50 loop-back test, the user must first press a key to decide if the test is to be performed. The display will show the following message:

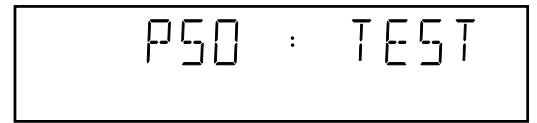

Figure 5-15

If the user presses STOP, the P50 test will be skipped. If the user presses OPEN/CLOSE, the P50 test is performed and the result is displayed as follows:

Test successful:

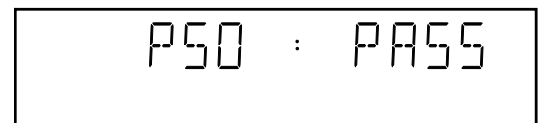

Figure 5-16

Test fails:

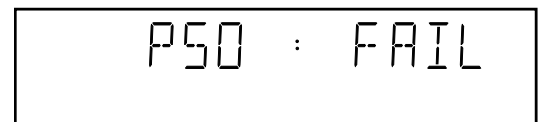

Figure 5-17

Press the PLAY key to continue to the next text

5.4 Mono PCB Digital Part

5.4.1 Picture Test

The picture test is performed by putting a predefined picture (colour bar) on the display (nucleus VideoColDencOn), and asking the user for confirmation.

The display will show the following message:

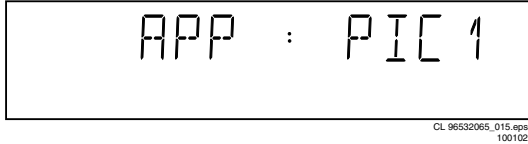

Figure 5-18

By pressing OPEN/CLOSE the user confirms the test, pressing STOP will indicate the picture was invisible or incorrect. Pressing PLAY will proceed to the next test. If the user presses PLAY without pressing OPEN/CLOSE or STOP first, the result of this test will be TRUE (picture ok).

Note: The colour bar must be simultaneously available on the CVBS, YC, and RGB (or YUV) outputs available. On the SCART only the CVBS and RGB signals will be available.

5.4.2 Sound 1 & SCART DVD Test

The first soundtest is performed by starting a pink noise sound that needs confirmation from the user (nucleus AudioPinkNoiseOn).

The display will show the following message:

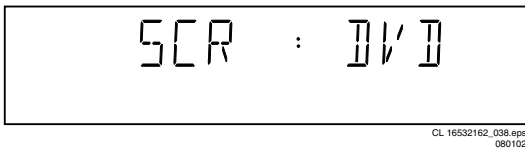

Figure 5-19

On the TV screen a colour bar (generated by nucleus VideoColDencOn) is visible and the internally generated pinknoise is audible.

By pressing the PLAY key, the user confirms the test.

Pressing the STOP key will indicate the sound was inaudible or incorrect.

Note: Only for double scart models, SCART loop-through will be simultaneously active during this test. SCART loop-through will be measured with the aid of an external video source.

By pressing the PLAY key, there will be switched over to the external source. This must become now visible on the TV screen (using the SCART).

The local display will show the following message:

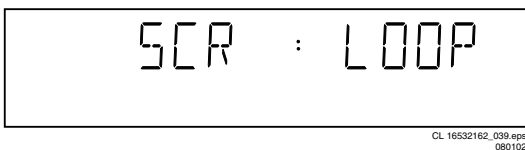

Figure 5-20

The internally generated colour bar is still available on the CVBS and Y/C outputs. And the pinknoise-signal is still available on the cinch audio outputs. By pressing the OPEN/CLOSE button, the internal generated colour bar becomes visual again.

The test can be left by pressing the PLAY key for more than one second.

5.4.3 Sound 2 Test

The second soundtest is performed by producing a sine sound (nucleus AudioSineOn). The signal can be stopped by pressing the STOP key.

The display will show the following message:

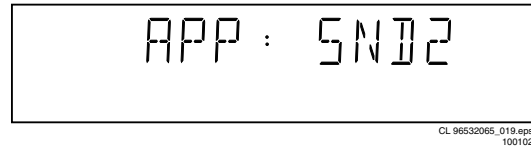

Figure 5-21

After the audio signal has been stopped, by pressing OPEN/CLOSE, the user confirms the test. Pressing STOP will indicate that something went wrong. Pressing PLAY will proceed to the next. If the user presses PLAY without pressing OPEN/CLOSE or STOP first, the result of this test will be TRUE (sound ok).

5.5 Basic Engine

5.5.1 Version Number

In the basic engine tests, the version number of the Basic Engine will be shown first, as the following example:

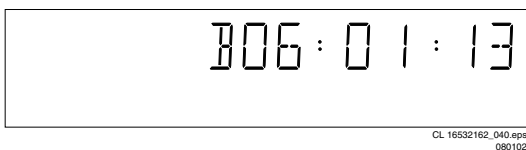

Figure 5-22

By pressing the PLAY key, the Basic Engine tests are started.

5.5.2 Tray Test

First, the tray is tested. The purpose of this test is also to give the user the opportunity to put a disc in the tray of the DVD player. Some tests on the Basic Engine require that a disc (e.g. DVD MPTD test disc) is present in the player. At the end of the Basic Engine tests this tray test will be repeated solely to enable the user to remove the disc in the tray. The local display will look as follows:

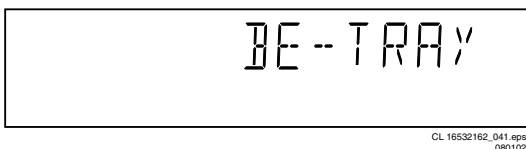

Figure 5-23

By pressing OPEN/CLOSE the user can toggle the position of the tray. Note that this test will not contribute to the test result of the Basic Engine. Pressing PLAY will proceed to the next test. At this point, the tray will be closed automatically by the software if it was open.

5.5.3 Sledge Test (Visual Test)

The second Basic Engine test tests the sledge. The user can move the sledge as many times as desired by using OPEN/CLOSE (nucleus BeSledgeOut) and STOP (nucleus BeSledgeIn). Pressing PLAY on the local keyboard proceeds to the next test. Note that this test will not contribute to the test result of the Basic Engine.

The local display will look as follows during the sledge test:

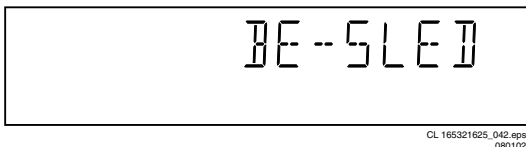

Figure 5-24

5.5.4 Disc Motor Test (Visual Test)

The third Basic Engine test tests the disc motor (nucleus BeDiscMotorOn).

The local display looks as follows:

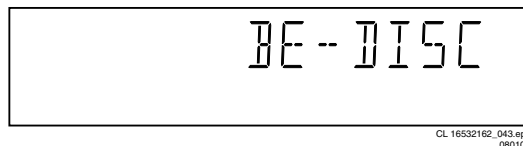

Figure 5-25

By pressing OPEN/CLOSE the user confirms that the disc motor is running. Pressing STOP indicates the disc motor does not work. Pressing PLAY proceeds to the next test, after a reset of the disc motor (nucleus BeDiscMotorOff). If the user presses PLAY before pressing OPEN/CLOSE or STOP, the result of this test will be TRUE (disc motor is running).

5.5.5 Focus Test (Visual Test)

The fourth Basic Engine test tests the focussing. First focussing is turned on by calling nucleus BeFocusOn. The display will look as follows:

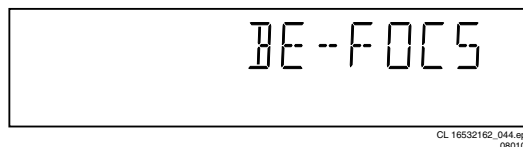

Figure 5-26

By pressing OPEN/CLOSE the user confirms that the focussing was successful. Pressing STOP indicates a focussing failure. Pressing PLAY proceeds to the next test after a reset of the focussing (nucleus BeFocusOff). If PLAY is pressed before OPEN/CLOSE or STOP, the result of this test will be TRUE (focus successful).

5.5.6 Radial Test (Visual & Listening Test)

The fifth Basic Engine test tests the radial functionality (nucleus BeRadialOn).

The local display looks as follows:

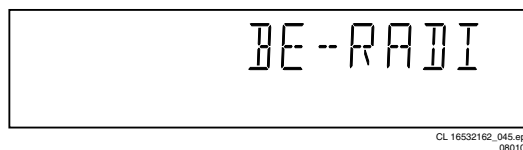

Figure 5-27

By pressing OPEN/CLOSE the user confirms that the radial function works. Pressing STOP indicates the function does not work. Pressing PLAY proceeds to the next test, after a reset of the radial (nucleus BeRadialOff). If the user presses PLAY before pressing OPEN/CLOSE or STOP, the result of this test will be TRUE (radial successful).

5.5.7 Jump Test (Listening Test)

The sixth and last Basic Engine test tests the jumping by calling nuclei BeGroovesIn, BeGroovesMid and BeGroovesOut. During this test, the local display looks as follows:

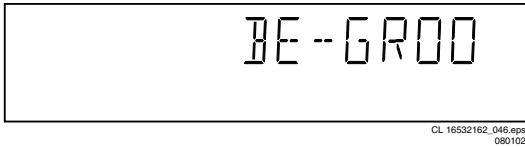

Figure 5-28

The user can switch between the three different types of groove settings by pressing OPEN/CLOSE (forward to next nucleus in the list In-Mid-Out), or STOP (backward in the list In-Mid-Out). This is done in a cyclic manner; note that this test will not contribute to the test result of the Basic Engine. Pressing PLAY proceeds to the next test, after the disc motor has been shut off with a call to nucleus BeDiscMotorOff.

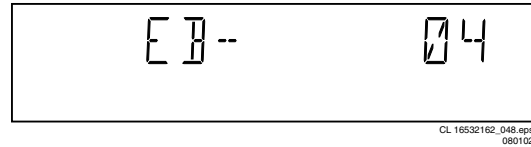

Figure 5-31

Only the identification number (decimal) representing set errorbits will be shown. By pressing OPEN/CLOSE or STOP, the user can move forward or backward (respectively) through the logged errorcodes. If the display only shows "EB-0", no error bits were set. By pressing PLAY the user can continue to the next test.

5.5.8 Tray Test

As a last action for the Basic Engine tests, the tray test is repeated. The local display will look as follows:

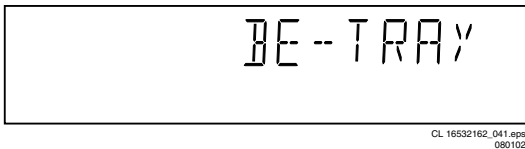

Figure 5-29

This test is meant to give the user the opportunity to remove the disc in the tray. The tray position can be toggled using the OPEN/CLOSE key. The tray will be closed (by the software, if it is open) before proceeding to the next test when the user presses the PLAY key.

5.5.9 Error Log (See Table on Page 25)

Reading the error log and error bits information can be useful to determine any errors that occurred recently during normal operation of the DVD player. Reading the error log is done by nucleus LogReadErr.

The display during the errorlog readout looks as follows :

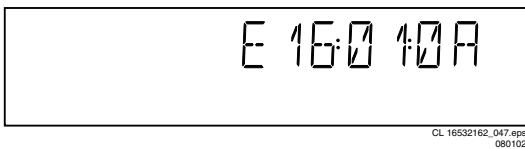

Figure 5-30

Note: Previous versions of the diagnostic software showed a 8-digit error code.

Due to limitations in the number of digits that can be displayed by some front panel displays, the most significant digits will not be shown. This can be done since all the error codes used by this player has set these 2 digits to "00"

By pressing OPEN/CLOSE or STOP the user can move forward or backward (respectively) through the logged error codes. If "0000" is displayed at all positions, the error log is empty. Display of the logged errors is done in a cyclic manner. By pressing PLAY on the local keyboard, the user can proceed to the next test.

5.5.10 Error Bits

Reading the error bits is done by nucleus LogReadBits. The display during the errorbits readout looks as follows:

5.6 Loop Test (See Table Below)

At the start of the loop test, the local display of the DVD player will show the interactive player test result readout in the following display:

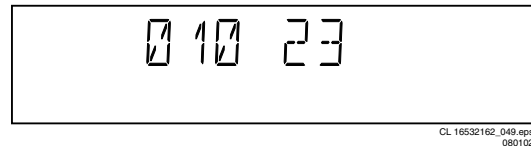

Figure 5-32

The left side of the display contains a 3-digit code, which can have a value between 000 and 111. These values indicate the faulty modules and are to be interpreted as follows:

Displayed Value	Indication for each module		
	Basic Engine	Mono PCB	Display PCB
000	ok	ok	ok
001	ok	ok	faulty
010	ok	faulty	ok
011	ok	faulty	faulty
100	faulty	ok	ok
101	faulty	ok	faulty
110	faulty	faulty	ok
111	faulty	faulty	faulty

CL 96532065_031.eps
120799

Figure 5-33

The loop test will perform the same nuclei as the dealer test, but it will loop through the list of nuclei indefinitely. The display of the DVD player will display not only the three digits indicating correct/faulty modules and the last found error code (as mentioned, faults are detected as far as they can be within the scope of the diagnostic software), but also a loop counter indicating how many times the loop has been gone through. If an error was detected, the display will remain as in figure 5-34 until the user presses the PLAY key and then it will continue to the next loop.

Example:

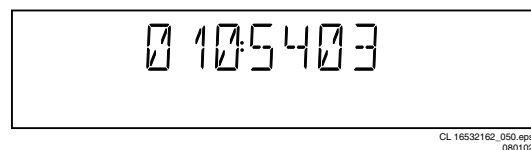

Figure 5-34

The 2-digit number (23) on the right of figure 5-32 indicates the number of times the loop test has been performed.

After one loop cycle: Display the 3-digit module bits together with the last error code which occurred in the loop test. The 4 digits at the right side of the display (fig. 5-34) show the last error that was found during the loop test. The leftmost two digits (54) of this code indicates which nucleus resulted in a fault. The rightmost two digits (03) refer to the faultcode within that nucleus. For further explanation of this error code, refer to chapter 5.8 (Nuclei Error Codes).

5.6.1 Errorlog

Explanation:

The application errors will be logged in the NVRAM. The maximum number of error bytes that will be visible is 16. The first word (4 digits) of the byte is the component identification, the last word is the error code.

The diagnostics software will present a combination of this component identification plus an error code on the local display (and on the attached terminal). The last reported error is shown as < 00000000, the oldest visible error as 00000000 > and the errors in between as < 00000000 >.

The devices that may report errors are the serial controller (UART), the basic engine (BE), the slave processor (SLPH), the SACD Stream Manager (SSM) and the SACD Media Access (SMA). The identification of these components is as follows:

Component name	Component identification
Serial controller (UART)	000A
Engine (BE)	0016
Slave Processor (SLPH)	001A
SACD Stream Manager (SSM)	001C
SACD Media Access (SMA)	002E
Diagnostic software (DS)	Dxxx

The tables in the next chapters list the error code and corresponding problem. The column 'Explanation' holds a more elaborate description and the most likely reason for the error.

Some Examples:

002E0000 (SMA reported a timeout error)
 0016010A (Engine could not fully close or open the tray)
 D0010001 (Flash checksum failed).

For further explanation of DS errors, see description of nuclei error codes in paragraph 5.8.

UART Error Codes

Error Number	Error name	Explanation
0000	BUF_OVE RFLOW	To many characters were offered in too little time. Reason: system was too busy doing other jobs.
0001	COMMUNI CATION	Usually a protocol error. Reason: bad connection between engine and processor.
0002	TIME OUT	

BE errors

Error Number	Error name	Explanation
0101	S2B_ILL_CO MMAND	Parameter(s) not valid for this command. Reason: some communication problem between UART and engine.
0102	S2B_ILL_PAR AM	Command not allowed in this state or unknown. Reason: see S2B_ILL_COMMAND error

Error Number	Error name	Explanation
0103	S2B_SLEDGE	Sledge could not be moved to home position.
0104	S2B_FOCUS	Focus failure
0105	S2B_MOTOR	Motor could not reach speed within timeout
0106	S2B_RADIAL	Servo didn't get on track after several retries.
0107	S2B_PLL_LO CK	PLL could not lock in Accessing or Tracking state
0108	SBC_HEADE R_TO	Header timeout
0109	S2B_SBC_NO T_FOUND	Requested subcode item could not be found.
010A	S2B_TRAY	Tray could not be opened or closed completely.
010B	S2B_TOC_RE AD	TOC could not be read within timeout period.
010C	S2B_JUMP	Requested seek could not be performed.
010D	S2B_NON_EX IST_SES	Attempt to access a non-existing session.
010E	S2B_NON_EX IST_BCA	Caller tries to acces a non-existing BCA area
010F	Speed setting	A wrong or inappropriate speed value has been set
0116	NO_DISC	No disc selected
011A	TRAY_INIT	After reset, initialized tray
011B	NO TOC INFO	No TOC information in lead-in area or erase TOC found
01F0	S2B_OVERR UN	Too many bytes received over S2B Reason: see S2B_ILL_COMMAND error
01F1	S2B_COMM_ TO	Not enough bytes are received over S2B Reason: see S2B_ILL_COMMAND error
01F2	S2B_PARITY	Byte received with parity error. Reason: see S2B_ILL_COMMAND error
01F3	S2B_ILL_PHA SE	CMD IDC is not valid, transmission out of sync. Reason: see S2B_ILL_COMMAND error
01F4	S2B_ILL_NR_ OF_BYTES	Byte count has an illegal value. Reason: see S2B_ILL_COMMAND error

SLPH Error Codes

Error Number	Error name	Explanation
0000	COMMUNICA TION	Error in I2C communication. Reason: bad connection between slave processor and main processor.

SSM Error Codes

Error Code	Error name	Explanation
0006	SP_SYNCER ROR	System cannot get synchronised with sectors coming from disc. Reason: Usually a damaged disc or the player was dropped/pushed during operation. If not, the engine is malfunctioning.
0007	SP_EDCERR OR	Data coming from disc is damaged. Reason: see SP_SYNCERROR

Error Code	Error name	Explanation
0008	SP_CONTINUITYERROR	Sequence of sectors coming from disc is incorrect. Reason: see SP_SYNCERROR
0009	DMX_CONTINUITYERROR	Sequence of sectors is incorrect. Reason: problem with buffer RAM
000A	LLD_ERROR	An illegal audio format was offered to the decoder. Reason: unknown audio type on disc or problem with buffer RAM
000B	BCU_ERROR	Internal problem in Furore chip

SMA Error Codes

Error Number	Error name	Explanation
0000	SMA_TIMEOUTERROR	Data coming from disc not in time. Reason: damaged disc or engine problem.

5.6.2 Reprogramming of New Mono Boards.**Caution**

This information is confidential and may not be distributed. Only a qualified service person should reprogram the mono board.

After reset of NV-memory or repair of the mono board, all the customer settings and also the region code will be lost.

Reprogramming of the mono board will put the player back in the state in which it has left the factory, i.e. with the default settings and the allowed region code.

Reprogramming is limited to 25 times

When the counter reaches 25, reprogramming is not possible anymore

Reprogramming will be done by way of the remote control.

Put the player in stop mode, no disc loaded.

Press the following keys on the remote control:

<PLAY> followed by numerical keys <1> <5> <9>

The display shows: “-----”

Press now successively the following keys :

```
for DVD620 /001 /021 /051 : <2><2><2> <0><0><1><0><0>
for DVD623 /001 /021 /051 : <2><2><2> <0><0><1><0><0>
for DVD633 /001 /021 /051 : <2><2><2> <0><0><1><0><0>
```

Press <PLAY> again.

The TV screen will become BLUE during a short time to confirm that the mono board has been reprogrammed.

Figure 5-35

5.6.3 Trade Mode

When the player is in Trade Mode, the player cannot be controlled by means of the front key buttons, but only by means of the remote control.

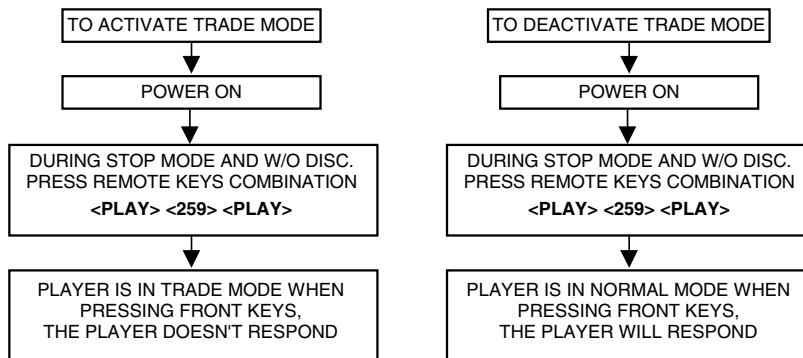

CL16532162_052.eps
0850102

Figure 5-36

Note: To activate and deactivate the Trade Mode with the disc in the player, the procedure is similar to above, except that the remote control keys combination is pressed at the instant when the local display is flashing "READING"

5.7 Menu and Command Mode Interface

5.7.1 Layout of Results Diagnostic Nuclei

Results returned from a Diagnostic Nucleus will be displayed in the following layout:

< number >< string > [ok | ER]

< number >: is a 4-digit decimal number padded with leading zeros if its value is less than 4 digits. The first 2 digits identify the generating nucleus (or group of nuclei) while the latter 2 digits indicate the error number.

< string >: is a text string containing information about the result of the Diagnostic Nucleus.

< number > and < string > are defined in [SSD_DN] in the output sections of each Nucleus.

Examples:

- 0001Unknown command ER @
- 3100OK @
- 0901Data line X is not connected to the DRAM ER @

5.7.2 Command Mode Interface

Set-up Physical Interface Components

Hardware required:

- Service PC
- one free COM port on the Service PC
- special cable to connect DVD player to Service PC

The service PC must have a terminal emulation program (e.g. OS2 WarpTerminal or Procomm) installed and must have a free COM port (e.g. COM1). Activate the terminal emulation program and check that the port settings for the free COM port are: 19200 bps, 8 data bits, no parity, 1 stop bit and no flow control. The free COM port must be connected via a special cable to the RS232 port of the DVD player. This special cable will also connect the test pin, which is available on the connector, to ground (i.e. activate test pin).

Code number of PC interface cable: 3122 785 90017

Activation

Switch the player on and the following text will appear on the screen of the terminal (program):

```
DVDv4 Diagnostic Software version 4.03
SDRAM Interconnection test passed
Basic SDRAM test passed
Front Panel Processor: SLAVE 4

(M)enu, (C)ommand (F)lash lguana or(S) 2B-interface?[M]:@ C
DD:>
```

Figure 5-37

The first line indicates that the Diagnostic software has been activated and contains the version number. The next lines are the successful result of the SDRAM interconnection test and the basic SDRAM test. The last line allows the user to choose between the three possible interface forms. If pressing C has made a choice for Command Interface, the prompt ("DD:>") will appear. The diagnostic software is now ready to receive commands. The commands that can be given are the numbers of the nuclei.

Command Overview of Nuclei

The following table gives an overview of all available nuclei. The first column contains an identification number, the second contains the name of a nucleus and the last column indicate the description of the nucleus.

Note: User confirmation is necessary during front panel tests

Basic Diagnostic Nuclei

Ref. #	Reference Name	Remark
1	BasicSpAcc	Serial port Access test/ initialization
2a	BasicInterconDram	Data and address bus Interconnection (only for development)
2b	BasicInterconSdram	Data and address bus interconnection
3	BasicDramWrR	DRAM Write Read (only for development)
4	BasicSdramWrR	SDRAM Write Read

Processor and Peripherals

Ref. #	Reference Name	Remark
6	PapChksFl	Checksum FLASH
8a	PapSgsAclCdda	Internal PLL CLK in CD-DA mode
8b	PapSgsAclDvd	Internal PLL CLK in DVD mode
8c	PapSgsAclDvd96	Internal PLL CLK in DVD (96kHz) mode
10	PapFlashWrAcc	FLASH Write Access (only for development)
11	PapI2cNvram	I2C NVRAM access
12	PapI2cDisp	I2C Display PWB
13	PapS2bEcho	S2B Echo
14	PapS2bPass	S2B Pass-through
15	PapNvramWrR	NVRAM Write Read
62	PapChksSum	Show checksums stored in flash

Components

Ref. #	Reference Name	Remark
16	CompSdramWrR	SDRAM Write Read

Audio

Ref. #	Reference Name	Remark
18a	AudioDeemp0On AudioDeempOn (DVD2B)	Audio De-emphasis 0 On Audio De-emphasis On (DVDv2B)
18b	AudioDeemp0Off AudioDeempOff (DVD2B)	Audio De-emphasis 0 Off Audio De-emphasis Off (DVDv2B)
19a	AudioMuteOn	Audio Mute On
19b	AudioMuteOff	Audio Mute Off
20a	AudioPinkNoiseOn	Audio Pinknoise On
20b	AudioPinkNoiseOff	Audio Pinknoise Off
21a	AudioSineOn	Audio Sine signal On/Off
21b	AudioSineBurst	Audio Sine signal Burst
56a	AudioLfePortHigh	Set the LFE_SEL port to HIGH
56b	AudioLfePortLow	Set the LFE_SEL port to LOW

Video

Ref. #	Reference Name	Remark
17a	VidPortOutAA	Output the value 0XAA at the Digital Video Interface Port
17b	VidPortOut55	Output the value 0X55 at the Digital Video Interface Port
23a	VideoColDencOnPAL	Colourbar (PAL) DENC On
23b	VideoColDencOff	Colourbar DENC Off

Ref. #	Reference Name	Remark
23c	VideoColDencOnNTSC	Colourbar (NTSC) DENC On
24a	VideoProgMPEGon	Progressive - DigitalVideo Colour Bar ON
24b	VideoYuvMPEGon	Enhanced YUV-DigitalVideo Colour Bar
25a	VideoScartLo	Scart Low
25b	VideoScartMi	Scart Medium
25c	VideoScartHi	Scart High
54	VideoScartSwComm	Scart Switch communication
55a	VideoScartSwDvd	Scart Switch Dvd
55b	VideoScartSwPass	Scart Switch Pass-through
57a	VideoScartPinLo	PIO-pins as used in 2A for Scart-switching
57b	VideoScartPinMi	PIO-pins as used in 2A for Scart-switching
57c	VideoScartPinHi	PIO-pins as used in 2A for Scart-switching
61a	VideoColOutRGB (ST5508)	Output RGB from ST5508
61b	VideoColOutYUV (ST5508)	Output YUV from ST5508

Display PWB (Slave Processor)

Ref. #	Reference Name	Remark
26	DispVer	Version number
27	DispKeyb	Keyboard
28	DispRc	Remote Control
29	DispLed	LEDs
30a	DispDisplay	VFT Display test
30b	DispLCDisplay	LCD Display test
30c	DispLCDBkLight	LCD Backlight test
60	DispP50	P50 loopback test

Log (Error Logging In NVRAM)

Ref. #	Reference Name	Remark
31	LogReadErr	Read last Errors
32	LogReadBits	Read errors Bits
33	LogReset	Reset

Miscellaneous

Ref. #	Reference Name	Remark
34	MiscReadConfig	Read Configuration area from NVRAM
35	MiscNvramReset	NVRAM Reset
36	MiscNvramMod	Modify NVRAM contents
46	MiscAppVer	Read version of application software
47a	MiscTrayOpenNr	Read the number of times the tray opened
47b	MiscPowerOnTime	Read the total time the player's power has been on
47c	MiscPlayTimeCddaVcd	Read the Playtime of CDDA and VCD discs
47d	MiscPlayTimeDvd	Read the Playtime of DVD discs

Basic Engine

Ref. #	Reference Name	Remark
37	BeVer	Version number
38a	BeFocusOn	Focus On
38b	BeFocusOff	Focus Off
39a	BeDiscmotorOn	Discmotor On
39b	BeDiscmotorOff	Discmotor Off
40a	BeRadialOn	Radial control On
40b	BeRadialOff	Radial control Off
41a	BeSledgeln	Sledge Inwards
41b	BeSledgeOut	Sledge Outwards
42a	BeGroovesIn	jump Grooves to Inside
42b	BeGroovesMid	jump Grooves to Middle
42c	BeGroovesOut	jump Grooves to Outside
43a	BeTrayIn	Tray In
43b	BeTrayOut	Tray Out
44	BeReset	Reset Basic Engine
58a	LaserCdOn	CD Laser on
58b	LaserCdOff	CD Laser off
58c	LaserDvdOn	DVD Laser on
58d	LaserDvdOff	DVD Laser off
59	AudioDtsCheckComm	Check I2C communication with Motorola DSP chip

Karaoke (Not Available)

Ref. #	Reference Name	Remark
48a	KaraokeModeOff	Switch Karaoke mode off
48b	KaraokeModeOn	Switch Karaoke mode on
49	KaraokeMicInput	Check path from the microphone input to audio output
50a	KaraokeKeyOn	Set Karaoke Key to the maximum level (1200 cent)
50b	KaraokeKeyOff	Set Karaoke Key to flat octave (0 cent)
51a	KaraokeEchoOn	Set Echo Control function on
51b	KaraokeEchoOff	Set Echo Control function off

5.7.3 Menu Mode Interface

Activation

Switch the player on and the following text will appear on the screen of the terminal (program):

```

DVDv4 Diagnostic Software version 4.03

SDRAM Interconnection test passed
Basic SDRAM test passed
Front Panel Processor: SLAVE 4

(M)enu, (C)ommand (F)lash Iguana or (S) 2B-interface? [M]:@ M
Press enter to go to main menu
CC:>
MAIN MENU

1 Audio ---
2 Video ---
3 Front Panel ---
4 Basic Engine ---
5 Processor Peripheral ---
6 Error Log ---
7 Miscellaneous ---

Select>

```

CL 16532162_054.dps
080102

Figure 5-38

The first line indicates that the Diagnostic software has been activated and contains the version number. The next lines are the successful result of the SDRAM interconnection test and the basic SDRAM test. The last line allows the user to choose

between the four possible interface forms. If pressing M has made a choice for Menu Interface, the Main Menu will appear.

Layout of Menu and Submenu

The following menu layout will appear after starting up the DVD player in menu mode. The symbol “- - -” indicates that the current menu choice will invoke the display of a submenu. The number between [] indicates the nucleus number. These numbers will not be shown on the screen.

Menus

MAIN MENU

- 1 Audio...
- 2 Video...
- 3 Front Panel...
- 4 Basic Engine...
- 5 Processor Peripherals...
- 6 Error Log...
- 7 Miscellaneous...

First Level Submenus

MAIN > AUDIO MENU

- 1 Mute...
- 2 Pink Noise...
- 3 Sine Wave...
- 4 Digital Ports...

MAIN > VIDEO MENU

- 1 Colourbar...
- 2 Scart...
- 3 Digital Port...

MAIN > FRONT PANEL MENU

- 1 Slave Processor...
- 2 VFT Display [30a]
- 3 LCD Display [30b]
- 4 LCD BkLight [30c]
- 5 Keyboard [27]
- 6 LEDs [29]
- 7 Remote Control [28]
- 8 P50 Check [60]

MAIN > BASIC ENGINE MENU

- 1 Reset [44]
- 2 Version [37]
- 3 S2B...
- 4 Loader Mechanism...
- 5 Special Diagnostics...

MAIN > PROCESSOR PERIPHERALS MENU

- 1 Clock...
- 2 Flash...
- 3 NVRAM...
- 4 SDRAM Write/Read [16]

MAIN > ERROR LOG MENU

- 1 Read Last Errors [31]
- 2 Read Error Bits [32]
- 3 Reset Error Log [33]

MAIN > MISCELLANEOUS MENU

- 1 Statistics Info...
- 2 Read DVD Application version [46]

Second level submenus

MAIN > AUDIO > MUTE MENU

- 1 Mute On [19a]
- 2 Mute Off [19b]

MAIN > AUDIO > PINK NOISE MENU

- 1 Pink Noise On [20a]
- 2 Pink Noise Off [20b]

MAIN > AUDIO > SINE WAVE MENU

- 1 Audio Sine On [21a]
- 2 Audio Burst On [21b]

MAIN > AUDIO > DIGITAL PORTS MENU

- 1 LFE_SEL High [56a]
- 2 LFE_SEL Low [56b]

MAIN > VIDEO > COLOURBAR MENU

- 1 Colourbar DENC On (PAL) [23a]
- 2 Colourbar DENC On (NTSC) [23c]
- 3 Colourbar DENC/MPEG Off [23b]
- 4 ProgressiveScan MPEG On [24a]
- 5 Enhanced YUV MPEG On [24b]
- 6 Set Video Out To RGB [61a]
- 7 Set Video Out To YUV [61b]

MAIN > VIDEO > SCART MENU

- 1 I2C Scart IC Check [54]
- 2 Scart To DVD [55a]
- 3 Scart Pass Through [55b]
- 4 Scart Pin 8 Low (0 to 2)V [25a]
- 5 Scart Pin 8 Mid (4.5 to 7)V [25b]
- 6 Scart Pin 8 Hi(9.5 to 12)V [25c]

MAIN > VIDEO > DIGITAL PORT MENU

- 1 Video Port Out 0xAA [17a]
- 2 Video Port Out 0x55 [17b]

MAIN > FRONT PANEL > SLAVE PROCESSOR MENU

- 1 Bus Comms Check [12]
- 2 S/W Version [26]

MAIN > BASIC ENGINE > S2B MENU

- 1 S2B Echo [13]
- 2 S2B Pass-Through [14]

MAIN > BASIC ENGINE > MECHANISM MENU

- 1 Disc Motor...
- 2 Laser...
- 3 Tray...
- 4 Focus...
- 5 Radial...
- 6 Sledge...
- 7 Grooves...

MAIN > BASIC ENGINE > SPECIAL DIAGNOSTICS MENU

- 1 Read FlashID [70]
- 2 ROM Checksum [71]

MAIN > PROCESSOR PERIPHERALS > PCM CLOCK MENU

- 1 PCM_CLK In CDDA Mode (11.3MHz) [8a]
- 2 PCM_CLK In DVD Mode (12.3MHz) [8b]
- 3 PCM_CLK In DVD96kHz Mode (24.6MHz) [8c]

MAIN > PROCESSOR PERIPHERALS > FLASH MENU

- 1 Verify FLASH Checksum [6]
- 2 Show FLASH Checksum [62]
- 3 Flash Write Access [10]

MAIN > PROCESSOR PERIPHERALS > NVRAM MENU

- 1 NVRAM Config [34]
- 2 NVRAM Reset [35]
- 3 NVRAM Modify [36]
- 4 NVRAM Read/Wr Test [15]

MAIN > MISCELLANEOUS > STATISTICS INFO MENU

- 1 Total Nr Of Times Tray Open [47a]

- 2 Total Time Power On [47b]
- 3 Total Play-Time CDDA & VCD [47c]
- 4 Total Play-Time DVD [47d]

Third level submenus

MAIN > BASIC ENGINE > MECHANISM > DISC MOTOR MENU

- 1 Disc Motor On [39a]
- 2 Disc Motor Off [39b]

MAIN > BASIC ENGINE > MECHANISM > LASER MENU

- 1 CD Laser On [58a]
- 2 CD Laser Off [58b]
- 3 DVD Laser On [58c]
- 4 DVD Laser Off [58d]

MAIN > BASIC ENGINE > MECHANISM > TRAY MENU

- 1 Tray Open [43b]
- 2 Tray Close [43a]

MAIN > BASIC ENGINE > MECHANISM > FOCUS MENU

- 1 Focus On [38a] (load DVD first)
- 2 Focus Off [38b]

MAIN > BASIC ENGINE > MECHANISM > RADIAL MENU

- 1 Radial Control On [40a] (load DVD first)
- 2 Radial Control Off [40b]

MAIN > BASIC ENGINE > MECHANISM > SLEDGE MENU

- 1 Sledge Inwards [41a]
- 2 Sledge Outwards [41b]

MAIN > BASIC ENGINE > MECHANISM > GROOVES (Uses DVD) MENU

- 1 Jump ToInside Grooves [42a]
- 2 Jump ToMiddle Grooves [42b]
- 3 Jump To Outside Grooves [42c]

5.8 Nuclei Error Codes

In the following tables the error description of the error codes will be described.

5.8.1 Audio Nuclei

Error code	Error text
1880	Test successful
1800	Test successful
1900	Test successful
1920	Test successful
2000	Test successful
2020	Test successful
2100	Test successful
5600	Test successful
5620	Test successful

5.8.2 Basic Engine Nuclei

Error code	Error text
3900	Test successful
3901	"Parity error from Basic Engine to Serial"
3902	"Unexpected response from Basic Engine"
3903	"Communication time-out error"
3904	"Basic Engine returned error number 0xXX"
3921	"Parity error from Basic Engine to Serial"
3922	"Unexpected response from Basic Engine"
3923	"Communication time-out error"
3924	"Basic Engine returned error number 0xXX"
3800	Test successful
3801	"Parity error from Basic Engine to Serial"
3802	"Unexpected response from Basic Engine"
3803	"Communication time-out error"
3804	"Basic Engine returned error number 0xXX"
3805	"Focus loop could not be closed"
3820	Test successful
3821	"Parity error from Basic Engine to Serial"
3822	"Unexpected response from Basic Engine"
3823	"Communication time-out error"
3824	"Basic Engine returned error number 0xXX"
4200	Test successful
4201	"Parity error from Basic Engine to Serial"
4202	"Unexpected response from Basic Engine"
4203	"Communication time-out error"
4204	"Basic Engine returned error number 0xXX"
4205	"Sledge could not be moved to home position"
4206	"Focus loop could not be closed"
4207	"Motor not on speed within time-out"
4208	"Radial loop could not be closed"
4209	"PLL could not lock in accessing or tracking state"
4210	"Subcode or sector information could not be read"
4211	"Requested subcode item could not be found"
4212	"TOC could not be read in time"
4213	"Seek could not be performed"
4220	Test successful
4221	"Parity error from Basic Engine to Serial"
4222	"Unexpected response from Basic Engine"
4223	"Communication time-out error"
4224	"Basic Engine returned error number 0xXX"
4225	"Sledge could not be moved to home position"
4226	"Focus loop could not be closed"
4227	"Motor not on speed within time-out"
4228	"Radial loop could not be closed"
4229	"PLL could not lock in accessing or tracking state"
4230	"Subcode or sector information could not be read"
4231	"Requested subcode item could not be found"
4232	"TOC could not be read in time"
4233	"Seek could not be performed"
4240	Test successful
4241	"Parity error from Basic Engine to Serial"

Error code	Error text
4242	"Unexpected response from Basic Engine"
4243	"Communication time-out error"
4244	"Basic Engine returned error number 0xXX"
4245	"Sledge could not be moved to home position"
4246	"Focus loop could not be closed"
4247	"Motor not on speed within time-out"
4248	"Radial loop could not be closed"
4249	"PLL could not lock in accessing or tracking state"
4250	"Subcode or sector information could not be read"
4251	"Requested subcode item could not be found"
4252	"TOC could not be read in time"
4253	"Seek could not be performed"
4000	Test successful
4001	"Parity error from Basic Engine to Serial"
4002	"Unexpected response from Basic Engine"
4003	"Communication time-out error"
4004	"Basic Engine returned error number 0xXX"
4005	"Radial loop could not be closed"
4020	Test successful
4021	"Parity error from Basic Engine to Serial"
4022	"Unexpected response from Basic Engine"
4023	"Communication time-out error"
4024	"Basic Engine returned error number 0xXX"
4400	Test successful
4401	Test successful
4100	Test successful
4101	"Parity error from Basic Engine to Serial"
4102	"Unexpected response from Basic Engine"
4103	"Communication time-out error"
4104	"Basic Engine returned error number XX"
4120	Test successful
4121	"Parity error from Basic Engine to Serial"
4122	"Unexpected response from Basic Engine"
4123	"Communication time-out error"
4124	"Basic Engine returned error number XX"
4300	Test successful
4301	"Parity error from Basic Engine to Serial"
4302	"Unexpected response from Basic Engine"
4303	"Communication time-out error"
4304	"Basic Engine returned error number 0xXX"
4320	Test successful
4321	"Parity error from Basic Engine to Serial"
4322	"Unexpected response from Basic Engine"
4323	"Communication time-out error"
4324	"Basic Engine returned error number 0xXX"
3700	"Version: X.Y.Z"
3701	"Parity error from Basic Engine to Serial"
3702	"Unexpected response from Basic Engine"
3703	"Communication time-out error"
3704	"Basic Engine returned error number 0xXX"
5800	Test successful

Error code	Error text
5820	Test successful
5840	Test successful
5860	Test successful
5801	"Unexpected response from Basic Engine"
7000	"Manuf. ID: <XX>" "Device ID: <YY>"
7001	"Comm Test Failed"
7002	"Load Cmd Failed"
7003	"Load Dat Failed"
7004	"Run Cmd Failed"
7100	"ROM Checksum: XXXX"
7101	"Comm Test Failed"
7102	"Load Cmd Failed"
7103	"Load Dat Failed"
7104	"Run Cmd Failed"

5.8.3 Display PWB Nuclei

Error code	Error text
3000	"Test successful"
3001	"Disp not responding"
3002	"Disp key no response"
3003	"One or more patterns not correct"
3004	"Disp type invalid"
3020	"Test successful"
3021	"Disp not responding"
3022	"Disp key no response"
3023	"One or more patterns not correct"
3040	"Test successful"
3041	"Disp not responding"
3042	"Disp key no response"
3043	"One or more patterns not correct"
2700	"Model name in wich the test is running"
2701	"Disp key no response"
2702	"Disp not responding"
2707	"Stop key not pressed"
2708	"Pause key not pressed"
2709	"Play key not pressed"
2710	"Open/close key not pressed"
2713	"Previous key not pressed"
2714	"Next key not pressed"
2715	"More than one key not pressed"
2716	" Audio key not pressed"
2900	"Test successful"
2901	"Slave not responding"
2902	"Slave keyboard not responding"
2903	"Standby led not working"
2800	"Test successful"
2801	"Slave display controller not responding"
2802	"Slave keyboard not responding"
2803	"No key press received from remote control"
2600	"The ROM version of the slave processor = 0xXX, and the internal ID = 0xYY"
2601	"I2c bus busy"
2602	"I2c bus not working"
6000	P50 test

Error code	Error text
6001	"No readback on P50"
6002	"Disp not responding "
6003	"P50 readback error"

5.8.4 Processor & Peripherals Nuclei

Error code	Error text
700	Test successful
720	Test successful
740	Test successful
600	"All checksums are correct"
601	"Following checksum is faulty: BootCode1 Checksum is 0xY2 and is not correct (must be 0xZ2)"
601	"This test is not available when stand-alone compiled"
6200	"Checksums = 0xA1, 0xB1, 0xC1, 0xD1"
6201	"This test is not available when stand-alone compiled"
1000	Test successful
1001	Test successful
1020	Test successful
1021	Test successful
1100	Test successful
1104	"NVRAM reply time-out"
1200	Test successful
1202	"Slave bus not working"
1203	"Slave controller not responding"
1204	"Slave response is not correct"
5900	Test successful
5901	"I2c bus busy"
5902	"I2c bus not working"
5904	"DTS chip response not correct"
1300	Test successful
1301	"Parity error from basic engine to serial"
1302	"Parity error from serial to basic engine"
1303	"No communication between serial and basic engine"
1304	"Communication time-out error"
1600	Test successful
1601	"The DVD SDRAM is faulty"

5.8.5 Log Nuclei

Error code	Error text
3100	"Show error log"
3101	"Error log is invalid"
3102	"Error log could not be read from NVRAM"
3103	"I2C bus busy before start"
3200	"Show error bit"
3201	"Error log is invalid"
3202	"I2C bus busy before start"

Error code	Error text
3203	"Error log could not be read from NVRAM"
3300	"Error log is cleared"
3301	"Error log could not be cleared"
3302	"I2C bus busy before start"

5.8.6 Miscellaneous Nuclei

Error code	Error text
3400	Test successful
3401	"The configuration data could not be read from NVRAM"
3402	"I2C bus busy before start"
3500	"NVRAM is cleared"
3501	"The NVRAM could not be reset."
3502	"I2C bus busy before start"
3600	"NVRAM contents updated."
	"NVRAM contents and configuration checksum updated."
3601	"NVRAM contents could not be updated."
3602	"I2C bus busy before start"
3603	"NVRAM contents could not be read"
3604	"NVRAM not accessible."
3605	"NVRAM checksum could not be updated."
1500	Test successful
1502	"NVRAM access time-out"
1504	"NVRAM fails"
5400	Test successful
5401	"I2c bus busy"
5402	"I2c bus not working"
5403	"Scart switch controller not responding"
5404	"Scart switch controller response not correct"
5500	Test successful
5501	"I2c bus busy"
5502	"I2c bus not working"
5520	Test successful
5521	"I2c bus busy"
5522	"I2c bus not working"
5523	"Scart switch controller not responding"
5200	Test successful
5201	"I2c bus busy"
5202	"I2c bus not working"
5300	Test successful
5301	"I2c bus busy"
5302	"I2c bus not working"
5320	Test successful
5321	"I2c bus busy"
5322	"I2c bus not working"
4700	"Number of times Tray went Open : XX"
4701	The total number of times tray went open could not be read from NVRAM.
4702	I2C bus busy before start

Error code	Error text
4720	"Total Power On time (minutes) : XX"
4721	The total power-on time could not be read from NVRAM.
4722	I2C bus busy before start
4740	"Total CDDA & VCD disks Play-time (minutes) : XX"
4741	The playtime of CDDA & VCD disks could not be read from NVRAM.
4742	I2C bus busy before start
4760	"Total DVD disks Play-time (minutes) : XX"
4761	The playtime of DVD disks could not be read from NVRAM.
4762	I2C bus busy before start
4600	"Version of Application Software : XX"
4601	"The application version could not be read from NVRAM."
4602	"I2C bus busy before start"

5.8.7 Video Nuclei

Error code	Error text
2300	Test successful
2320	Test successful
2340	Test successful
2400	Test successful
2401	"I2c bus busy"
2421	"I2c bus busy"
2441	"I2c bus busy"
2500	Test successful
2501	"I2c bus busy"
2502	"I2c bus not working"
2520	Test successful
2521	"I2c bus busy"
2522	"I2c bus not working"
2540	Test successful
2541	"I2c bus busy"
2542	"I2c bus not working"
6100	Test successful
6100	Test successful

5.9 Test Instruction Motherboard

These test instruction is designed specifically for VFM2002 motherboard which has the following outputs:

- Audio L/R
- Coaxial digital output
- CVBS
- SCART output
- Front display

5.9.1 General

- All the waveforms measurement carried out in these test instruction will be base on the testpoint indicated in the motherboard schematic diagram in the Service manual.
- Impedance of the measuring-equipment should be $> 1M\Omega$
- Most of the tests can be done using either the Diagnostic software "Player script" which can be found in the chapter "Diagnostic Software description and troubleshooting" or the Menu interface using the Service PC with a terminal emulation program (e.g. Window Hyperterminal) where it is possible to control the execution of the Diagnostic Nuclei
- Setup for the measurement will be done in set level with all modules connected as shown in the Wiring Block diagram.

5.9.2 General Start-Up Measurement

Supply Check:

Before starting the measurement,ensure that all power supply are connected to the motherboard via conn.1400 and 1401.

Pin nr.	Voltages	
	Conn. 1400	Conn. 1401
1	+5VSTBY	+3V3STBY
2	+12VSTBY	+3V3STBY
3	DGND	DGND
4	-32V	+12VSTBY
5	NA	DGND
6	NA	+5VSTBY
7	NA	DGND
8	NA	-8V

Clock Check

Ensure the present of the clock to the DAC and slave uP

Clock Name	Testpoint	Frequency
PCM_CLK	I173	11.2896MHz \pm 0.02% tolerance
XOUT	I325	8MHz \pm 0.2% tolerance

Audio Mute Check

Measure the Audio mute voltage input at pin 22 of connector 1100

Status	Value
AudioMuteOn	HIGH (>3V)
AudioMuteOff	LOW (<3V)

To toggle between ON and OFF,use the following commands:

Ref.#	Command Name	Remarks
19a	AudioMuteOn	Audio Mute On
19b	AudioMuteOff	Audio Mute Off

5.9.3 Audio DAC And Amplifier

Ensure that the Audio mute signal is OFF

To check the DAC and buffer amplifier,send the following commands:

Ref.#	Command Name	Remarks	Audio output
21a	AudioSineOn	Audio Sine signal ON	Sine,1KHz on stereo
----	Press stop button	Audio Sine signal OFF	No waveform
20a	AudioPinkNoiseOn	Audio Pinknoise ON	Pink Noise on 6 channels
20b	AudioPinkNoiseOff	Audio Pinknoise OFF	No waveform

The audio signal (sine or pink noise) will also be present on the digital output (SPDIF).This can be checked by connecting digital signal to an amplifier with digital input.

Check the I2S and audio signal at the following testpoints:

Name	Testpoint
PCM_LRCLK	I172
PCM_SCLK	I176
PCM_CLK	I173
PCM_DATA0	I174
PCM_DATA1	NA
PCM_DATA2	NA
DIG_OUT	I254
AUDIO L/R OUT	I241 / I221
FRONT L/R OUT	NA
SURROUND L/R OUT	NA
CENTRE OUT	NA
SUB WOOFER L/R OUT	NA

All waveforms can be referred to the motherboard schematic diagram.

5.9.4 Video Output And Buffer Amplifier

Check DC output-level at all video cinch output : 1.0V DC \pm 10%

Generate a color bar using the following software commands:

Ref.#	Command Name	Remarks
23a	VideoColDencOn	Colour DENC ON
23b	VideoColDencOff	Colourbar DENC OFF

Check the video outputs at the following testpoints:

Name	Testpoint
BLUE	I186
GREEN	I185
RED	I184
CVBS out	I180 / I165 / I145
S-Video-C out	NA
S-Video-Y out	NA

Il waveforms can be referred to the motherboard schematic diagram.

5.9.5 Play and 16/9 Detection

Check 0/6/12 signal on pin 8 of the SCART connector 1130 and change the SCART_0 and SCART_1 input with the following commands:

Ref.#	Command Name	Remarks
25a	VideoScartLo	Sends out 0V \pm 0.5V
25b	VideoScartMi	Sends out 6V \pm 10%
25c	VideoScartHi	Sends out 12V \pm 10%

5.9.6 Kill Circuit

To check the functionality of the Kill circuitry,the audio outputs has to be present by the following command:

Ref.#	Command Name	Remarks	Audio output
21a	AudioSineOn	Audio Sinewave ON	1kHz tone

Check the audio outputs at the audio cinch of the motherboard: 1kHz tone

Activate the Kill circuit by using the following command:

Ref.#	Command Name	Remarks
19a	AudioMuteOn	Audio Mute On

Check the audio outputs at the audio L/R cinch and SCART of the motherboard: No waveform

Switch off the kill circuit by using the following command:

Ref.#	Command Name	Remarks
19b	AudioMuteOff	Audio Mute Off

Check the audio outputs at the audio L/R cinch and SCART of the motherboard: 1kHz tone

5.9.7 Digital Silence

Digital silence is a signal from the audio DAC, KILL_LR, when there is no input to the audio DAC, or when the player is in STOP/PAUSE mode, or during disc changing track.

To check the KILL_LR signal, use the following command and check the voltage level at pin 16 of 7200:

Ref.#	Command Name	Remarks	KILL_LR signal
21a	AudioSineOn	Audio Sinewave ON	LOW (<0.3V)
---	Press STOP button	Audio Sine signal OFF	HIGH (>4.5V)

5.9.8 Front Display

To check the segment display of the FTD, the following command can be used. And for full detail description of the test, refer to the chapter of "Diagnostic Software Player Script" which can be found in chapter "Diagnostic Software Description and Troubleshooting"

Ref.#	Command Name	Remarks
30a	DispDisplay	Turn ON local display

5.9.9 IR Receiver

Check at pin 22 of 7300 and observe if this line switches from LOW (<0.3V) to HIGH (>4.5V) when pressing a key on a philips RC5 or RC6 remote control

6. Block and Wiring Diagram.

Block Diagram VFM2002 EU

GENERAL BLOCK DIAGRAM VFM2002 EU

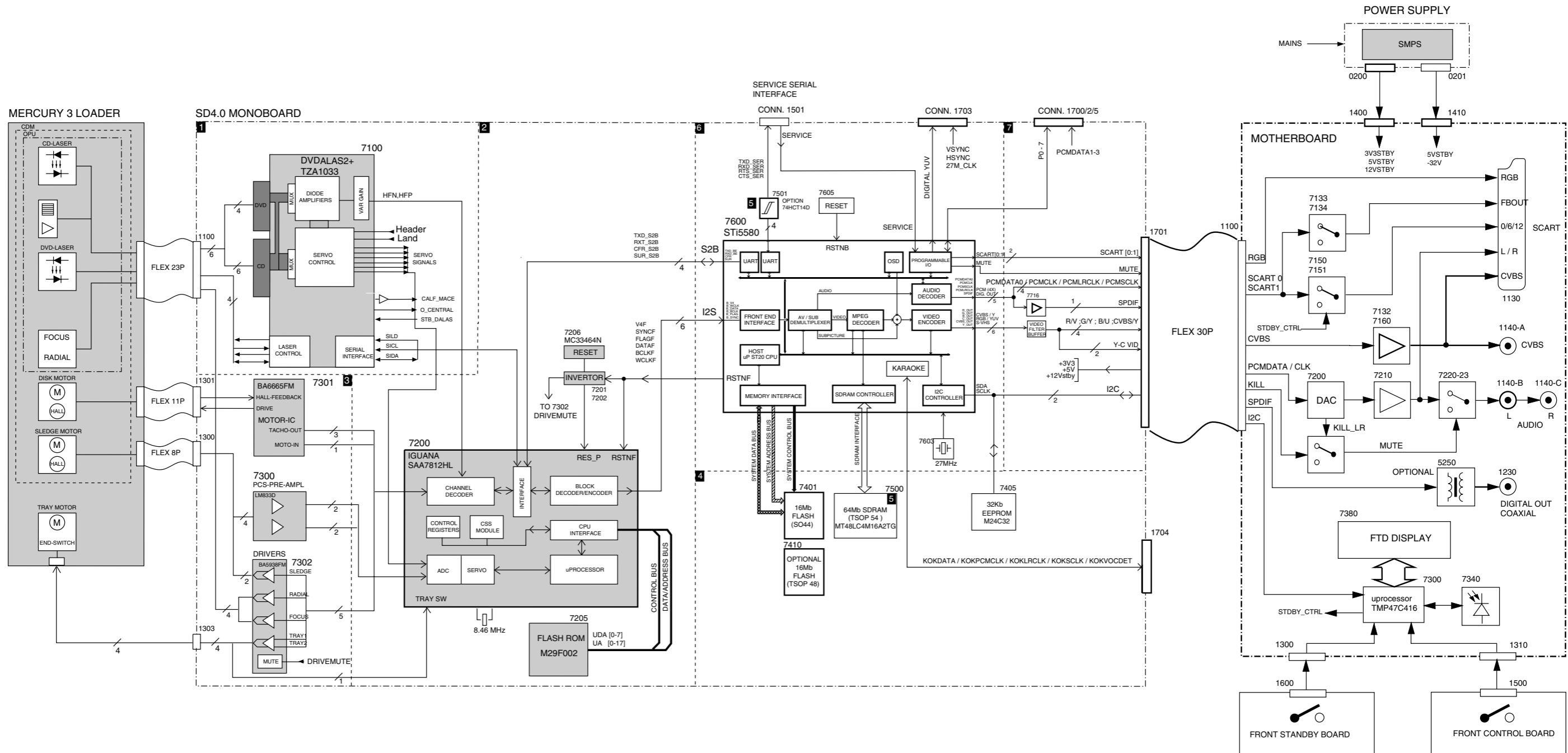

Wiring Diagram

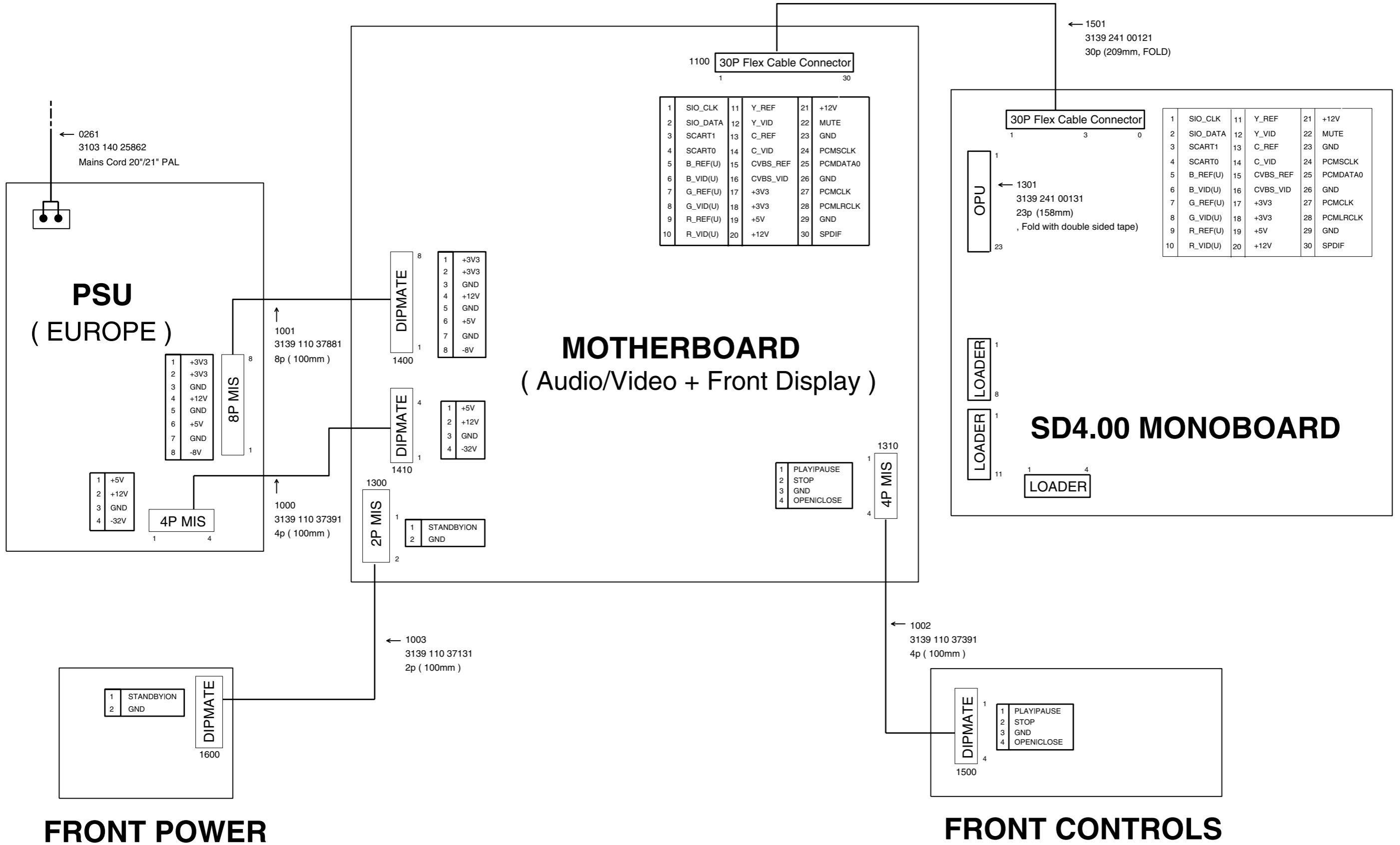

NOTE : Wires with Item no. 1800 - 1803 are single open-ended soldered to PCB

\$PROJECT/DVD_2002/doc/3139_249_21461

7. Electrical Diagrams and Print-Layouts

Power Supply Unit VFM 2002 EURO

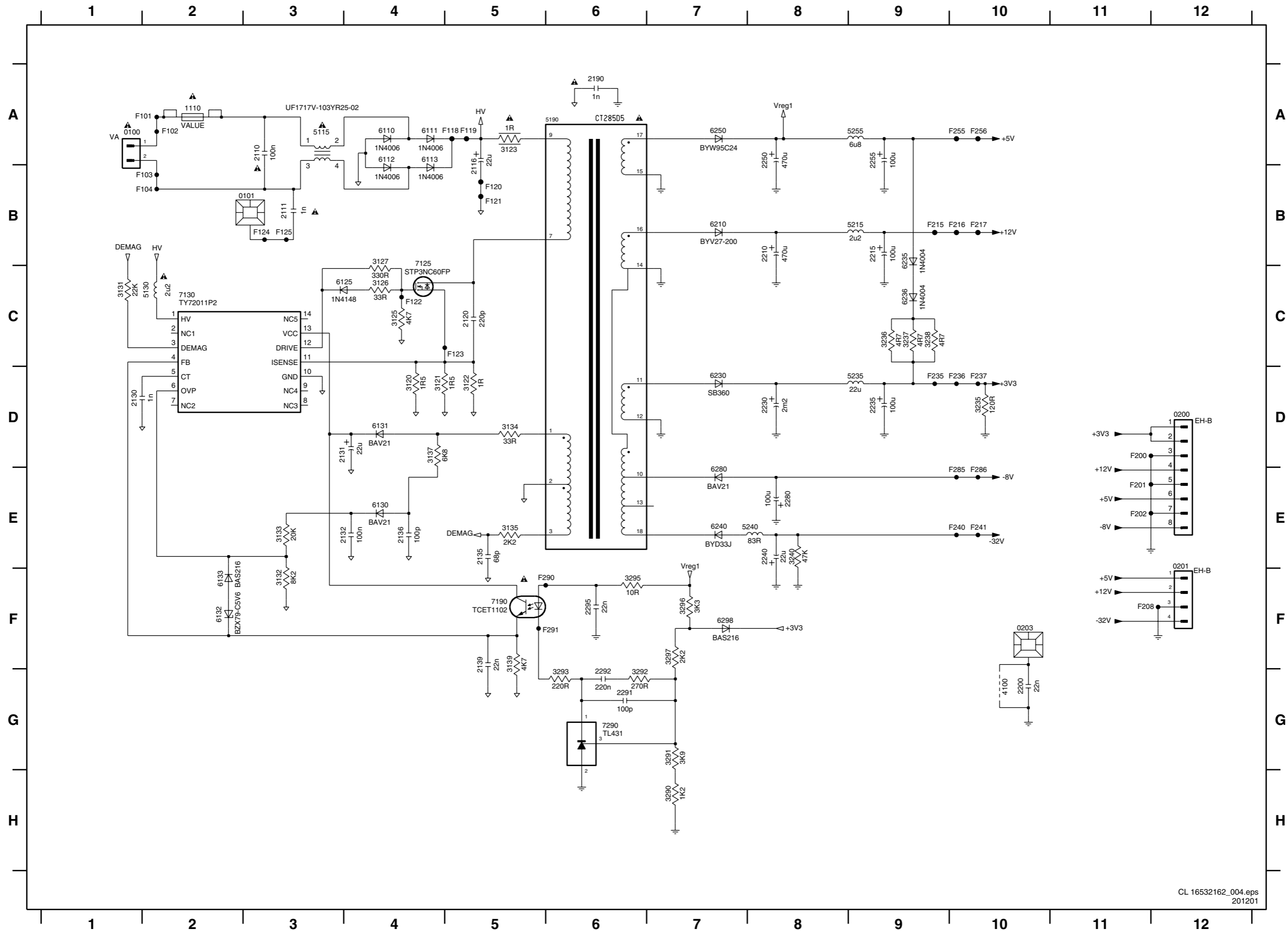

- 0100 A1
- 0101 B2
- 0200 D12
- 0201 F12
- 0203 F10
- 1110 A2
- 2110 A3
- 2111 B3
- 2116 B5
- 2120 C5
- 2130 D1
- 2131 D4
- 2132 E4
- 2135 E5
- 2136 E4
- 2139 F5
- 2190 A6
- 2200 G10
- 2210 B8
- 2215 B9
- 2230 D8
- 2235 D9
- 2240 E8
- 2250 A8
- 2255 A9
- 2280 E8
- 2291 G6
- 2292 G6
- 2295 F6
- 3120 D4
- 3121 D4
- 3122 D5
- 3123 A5
- 3125 C4
- 3126 C4
- 3127 B4
- 3131 C1
- 3132 F3
- 3133 E3
- 3134 D5
- 3135 E5
- 3137 D4
- 3139 F5
- 3235 D10
- 3237 C9
- 3238 C9
- 3240 E8
- 3290 H7
- 3291 G7
- 3292 G6
- 3293 G6
- 3295 F6
- 3296 F7
- 3297 F7
- 4100 G10
- 5130 C2
- 5130 C2
- 5190 A6
- 5215 B9
- 5235 D9
- 5240 E8
- 5255 A9
- 6110 A4
- 6111 A4
- 6112 A4
- 6113 A4
- 6125 C4
- 6130 E4
- 6131 D4
- 6132 F2
- 6133 F2
- 6210 B7
- 6230 D7
- 6235 B9
- 6236 C9
- 6240 E7
- 6250 A7
- 6280 E7
- 6298 F7
- 7125 C4
- 7130 C2
- 7190 F5
- 7290 G6
- F101 A2
- F102 A2
- F103 B2
- F104 B2
- F118 A5
- F119 A5
- F120 B5
- F121 B5
- F122 C4
- F123 C5
- F124 B3
- F125 B3
- F200 D11
- F201 E11
- F202 E11
- F208 F11
- F215 B9
- F216 B10
- F217 B10
- F235 D9
- F236 D10
- F237 D10
- F240 E10
- F241 E10
- F255 A10
- F256 A10
- F285 E10
- F286 E10
- F290 F6
- F291 F6

Layout Power Supply VFM2002 EU (Top View)

0100 B1	2116 B1	2240 A3	3123 B2	5255 B3	6132 A1	6280 B3	9200 A3
0101 B1	2120 A2	2250 B3	3131 A2	6110 B1	6210 B3	7125 B2	9201 A3
0200 A3	2131 A2	2255 A3	5115 B1	6111 B1	6230 B3	7130 A1	9202 A3
0201 A3	2190 B2	2280 B3	5130 A2	6112 B2	6235 A3	7190 A2	9203 A3
0203 B3	2210 B3	3110 A1	5190 B2	6113 B2	6236 A3	7290 A3	
1110 B1	2215 A3	3120 A1	5215 B3	6125 A1	6240 A2	9100 B2	
2110 B1	2230 B3	3121 A1	5235 B3	6130 A2	6250 B3	9101 A1	
2111 B1	2235 B3	3122 A1	5240 A3	6131 A2	6251 B3	9102 A2	

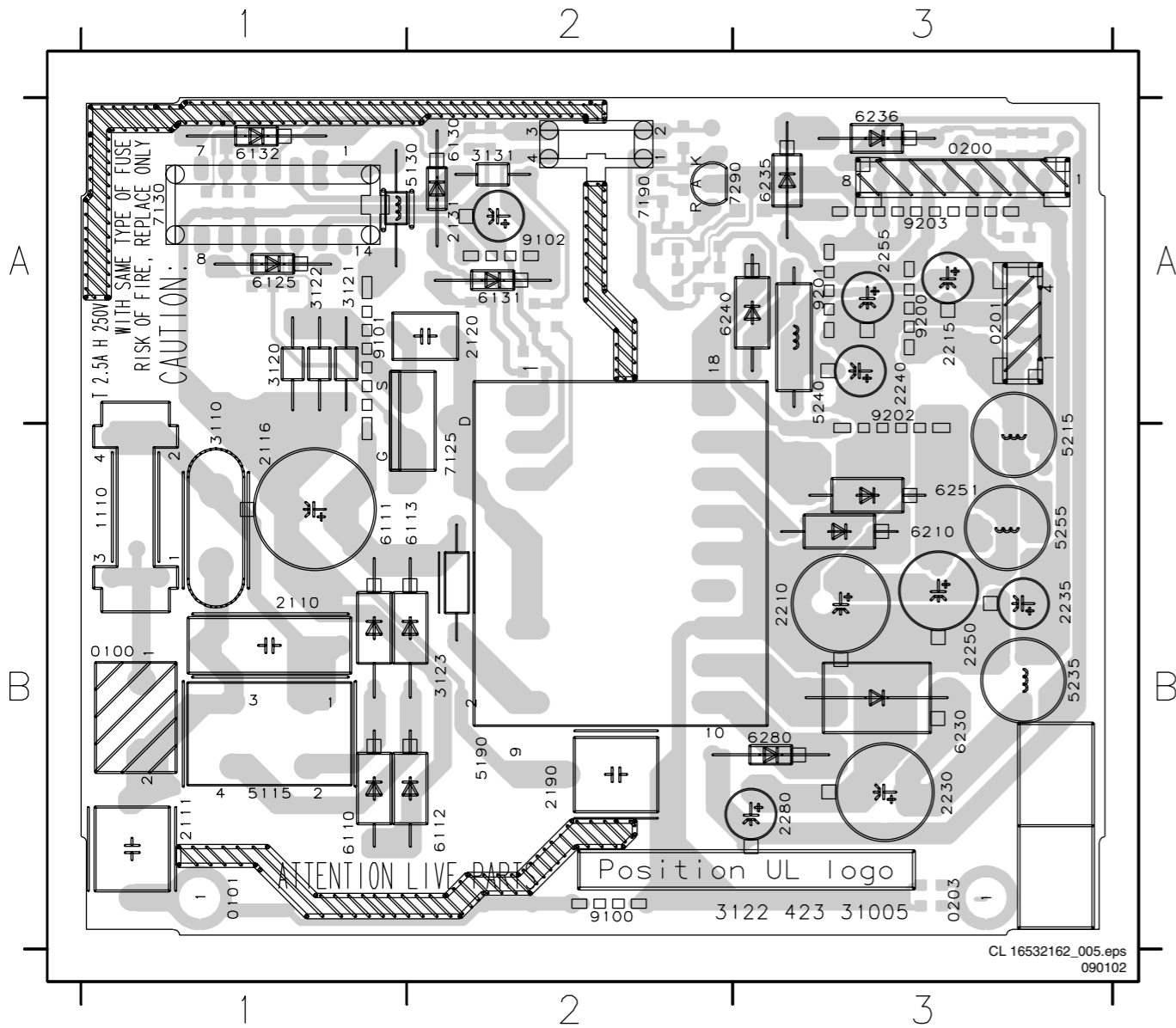

Layout Power Supply VFM2002 EU (Bottom View)

2130 B1	2139 B2	2295 B2	3132 B1	3136 B2	3236 B3	3290 B2	3295 B2	6133 B1
2132 B1	2200 A3	3125 B1	3133 B1	3137 B2	3237 B3	3291 B2	3296 B2	6298 B3
2135 B2	2291 B2	3126 B1	3134 B2	3139 B2	3238 B3	3292 B2	3297 B2	
2136 B2	2292 B2	3127 B1	3135 B2	3235 B3	3240 B3	3293 B2	4100 A3	

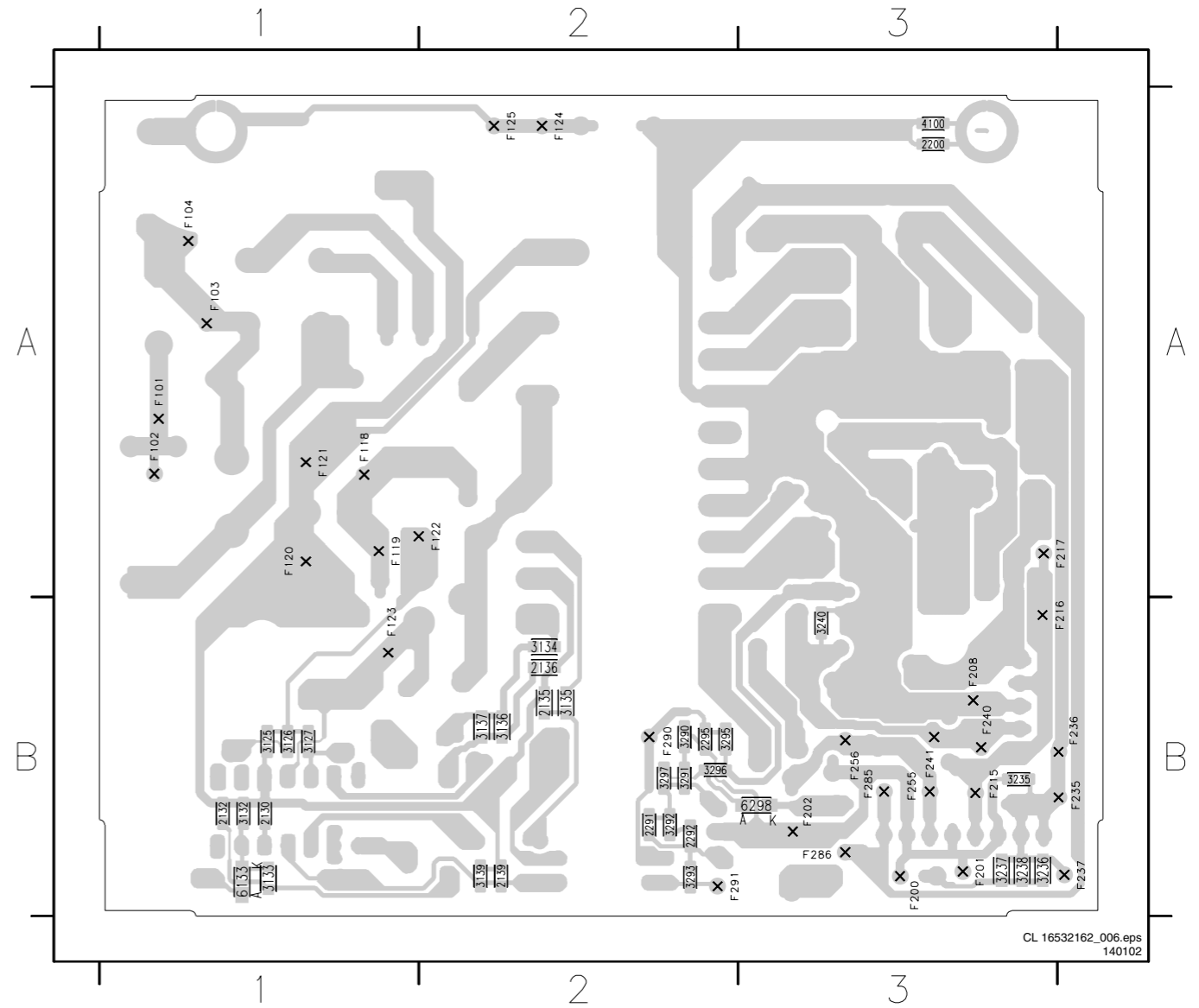

Mother Board: Video & SCART

A 1 VIDEO & SCART

A 1

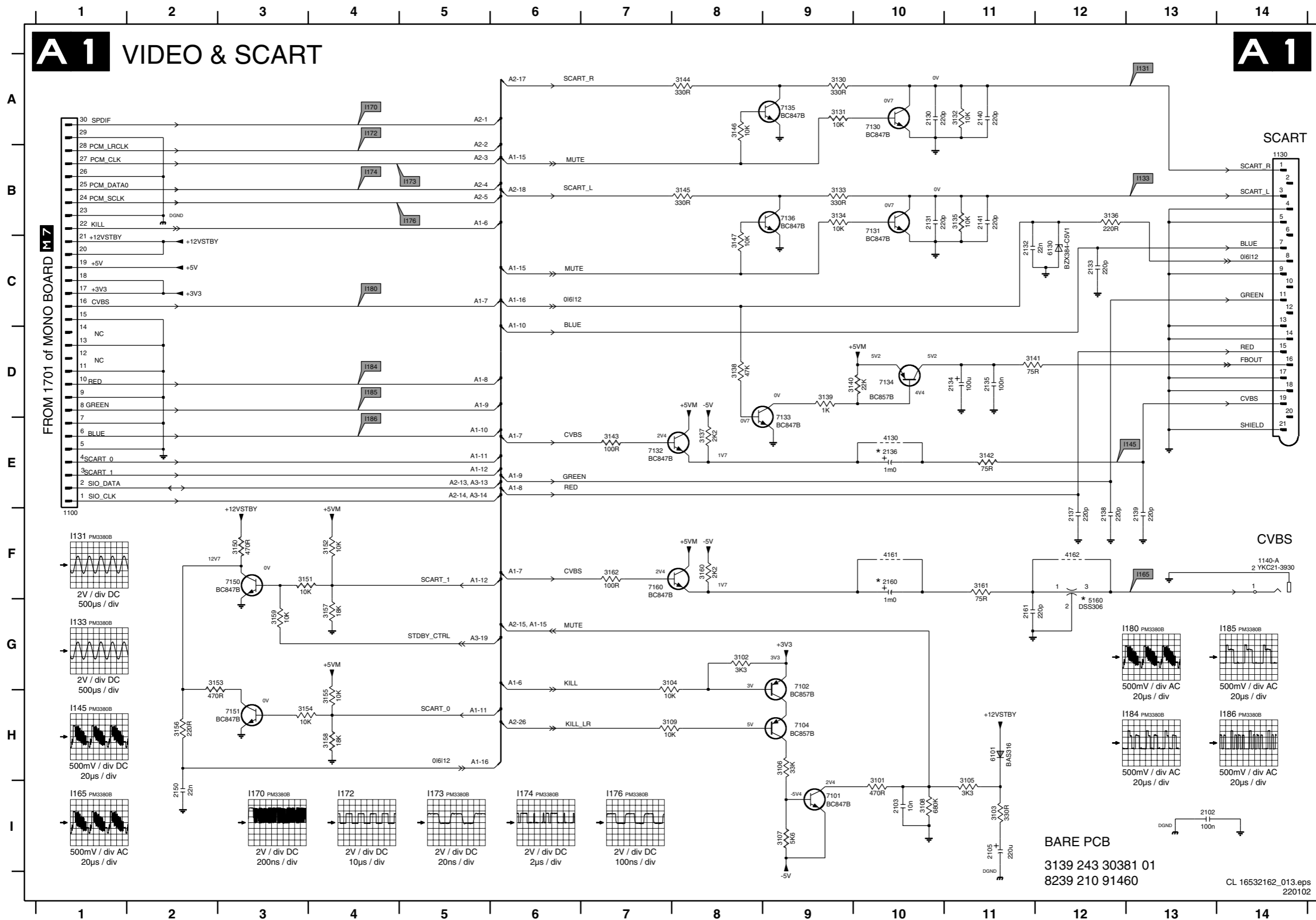

- 1100 F1
- 1130 B14
- 1140-A F14
- 2102 I13
- 2103 I10
- 2105 I11
- 2130 A10
- 2131 B10
- 2132 C11
- 2133 C12
- 2134 D11
- 2135 D11
- 2136 E10
- 2137 F12
- 2138 F12
- 2139 F13
- 2140 A11
- 2141 B11
- 2150 I2
- 2160 F10
- 2161 G11
- 3102 G8
- 3103 I11
- 3104 G7
- 3105 I11
- 3106 H9
- 3107 I9
- 3108 I10
- 3109 H7
- 3130 A9
- 3131 A9
- 3132 A11
- 3133 B9
- 3134 B9
- 3135 B11
- 3136 B12
- 3137 E8
- 3138 D8
- 3139 D9
- 3140 D9
- 3141 D11
- 3142 E11
- 3143 E7
- 3144 A8
- 3145 B8
- 3146 A8
- 3147 C8
- 3150 F3
- 3151 F3
- 3152 F4
- 3153 G2
- 3154 H3
- 3155 H4
- 3156 H2
- 3157 G4
- 3158 H4
- 3160 F8
- 3161 F11
- 3162 F7
- 4130 E10
- 4161 F10
- 4162 F12
- 5160 G12
- 6101 H11
- 6130 C12
- 7101 I9
- 7102 G9
- 7104 H9
- 7130 A10
- 7131 B10
- 7132 E7
- 7133 E9
- 7134 D10
- 7135 A9
- 7136 B9
- 7150 F3
- 7151 H3
- 7160 F7

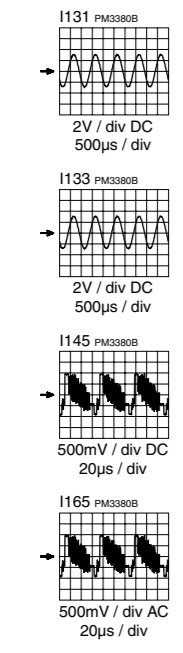

BARE PCB
3139 243 30381 01
8239 210 91460

CL 16532162_013.eps
220102

* Reserved Parts
V DC voltage measured in STOP_MODE

Mother Board: Audio

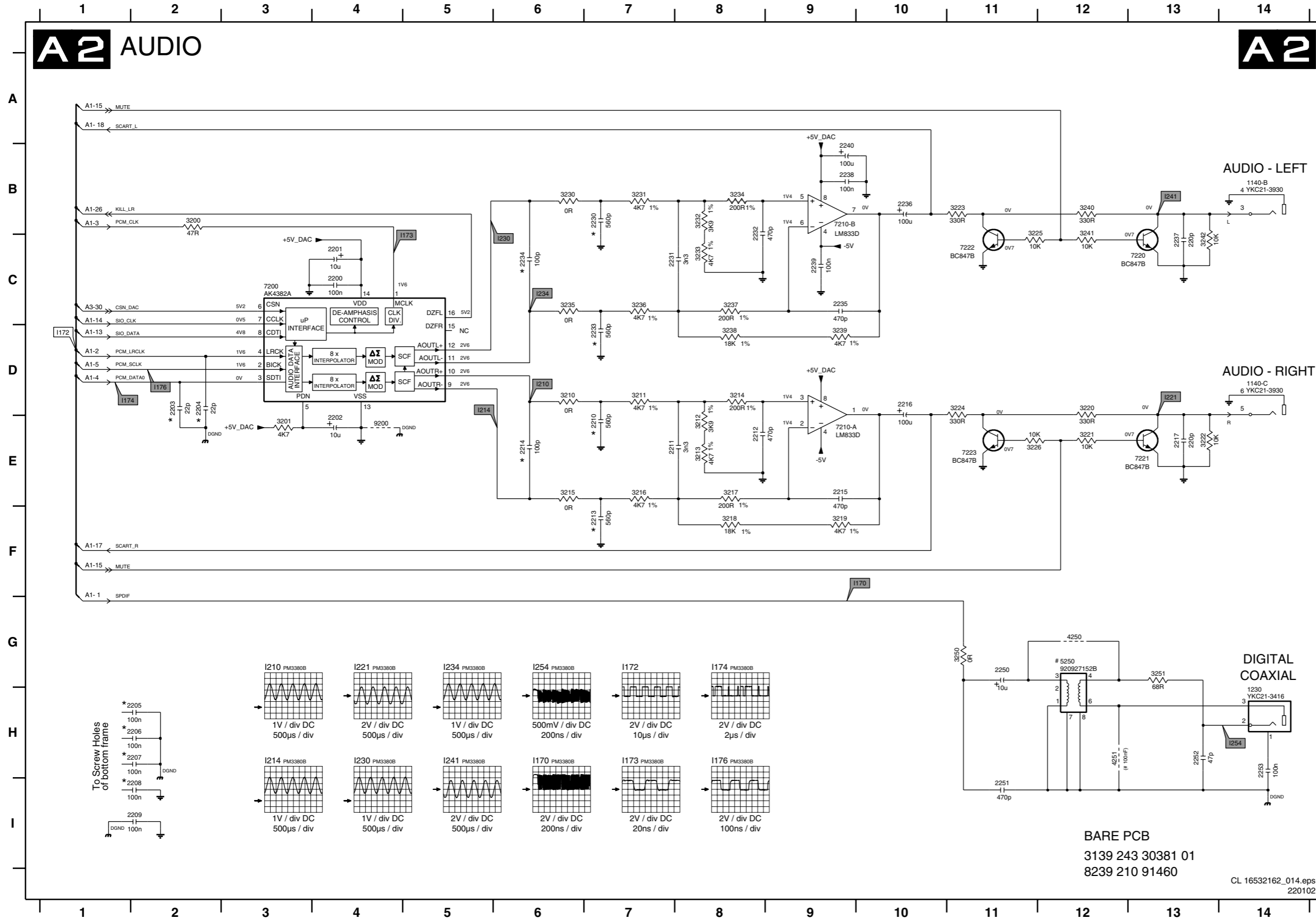

1140-B	B14	3240	B12
1140-C	D14	3241	C12
1230	H14	3242	C13
2200	C4	3250	G11
2201	C4	3251	G13
2202	E4	4250	H12
2203	D2	4251	H12
2204	D2	5250	G12
2205	H2	7200	C3
2206	H2	7210-A	E9
2207	H2	7210-B	B9
2208	I2	7220	C13
2209	I1	7221	E13
2210	E7	7222	C11
2211	E7	7223	E11
2212	E8	9200	E4
2213	F7		
2214	E6		
2215	E9		
2216	D10		
2217	E13		
2230	B7		
2231	C7		
2232	B8		
2233	D7		
2234	C6		
2235	C9		
2236	B10		
2237	C13		
2238	B9		
2239	C9		
2240	B9		
2250	G11		
2251	I11		
2252	H13		
2253	H14		
3200	B2		
3201	E3		
3210	D6		
3211	D7		
3212	E8		
3213	E8		
3214	D8		
3215	E6		
3216	E7		
3217	E8		
3218	F8		
3219	F9		
3220	D12		
3222	E13		
3223	B11		
3224	D11		
3225	C11		
3226	E11		
3230	B6		
3231	B7		
3232	B8		
3233	C8		
3234	B8		
3235	C6		
3236	C7		
3237	C8		
3238	D8		
3239	D9		

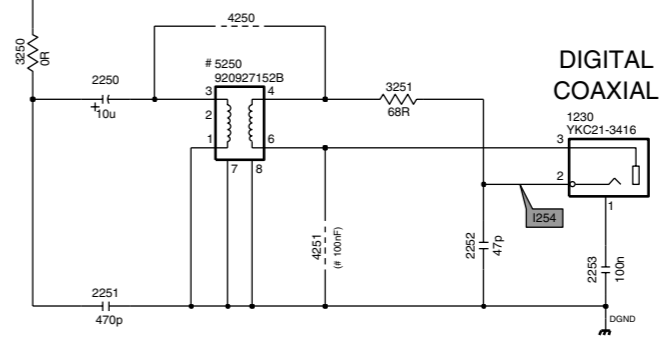
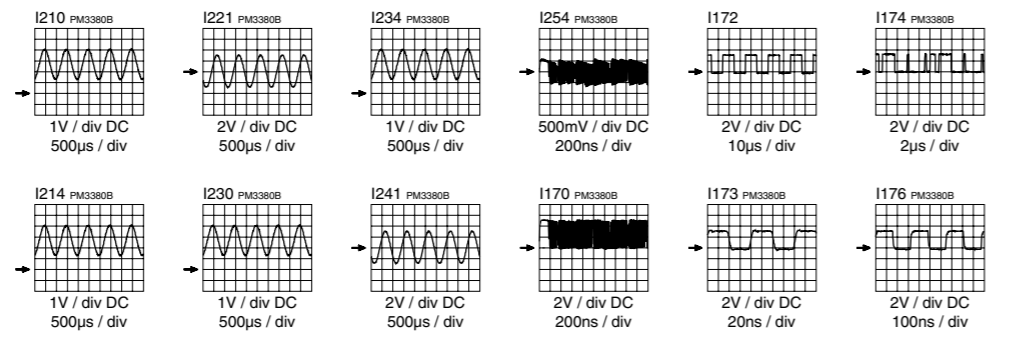

BARE PCB
3139 243 30381 01
8239 210 91460

CL 16532162_014.eps
220102

Optional for balanced output
V DC voltage measured in STOP mode
* Reserved Parts

Mother Board: Front

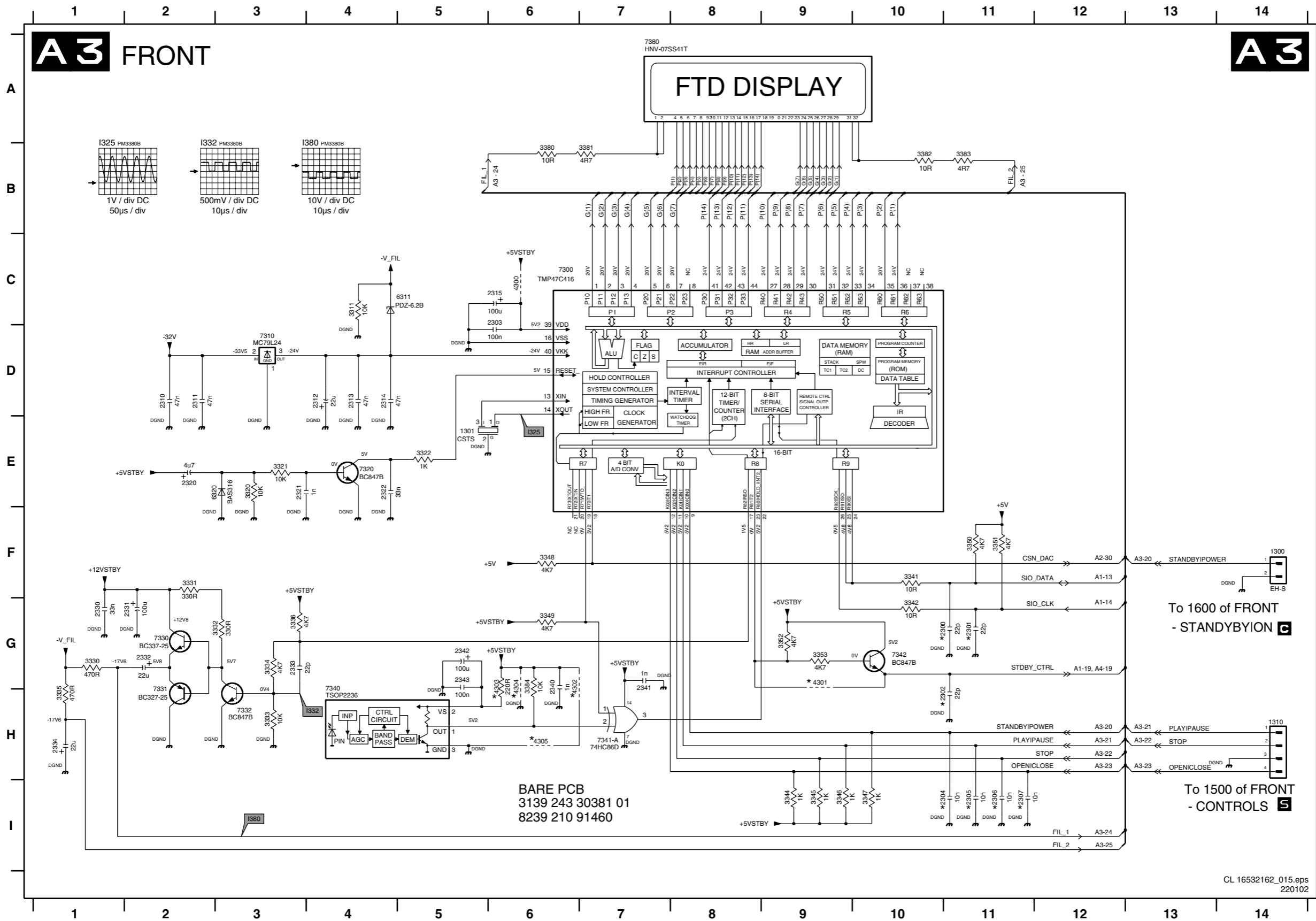

A3

A3 FRONT

- 1300 F14
- 1301 E5
- 1310 H14
- 2300 G11
- 2301 G11
- 2302 H11
- 2303 C6
- 2304 I11
- 2305 I11
- 2306 I11
- 2307 I11
- 2310 D2
- 2311 D2
- 2312 D4
- 2313 D4
- 2314 D4
- 2315 C6
- 2320 E2
- 2321 E3
- 2322 E4
- 2330 G1
- 2331 G2
- 2332 G2
- 2333 G3
- 2334 H1
- 2340 G6
- 2341 G7
- 2342 G5
- 2343 G5
- 3311 C4
- 3320 E3
- 3321 E3
- 3322 E5
- 3330 G1
- 3331 F2
- 3332 G3
- 3333 H3
- 3334 G3
- 3335 H1
- 3336 G3
- 3341 F10
- 3342 G10
- 3344 I9
- 3345 I9
- 3346 I9
- 3347 I10
- 3348 F6
- 3349 G6
- 3350 F11
- 3351 F11
- 3352 G9
- 3353 G9
- 3380 B6
- 3381 B7
- 3382 B10
- 3383 B11
- 4300 C6
- 4301 G9
- 4302 G6
- 4303 G6
- 4304 G6
- 4305 H6
- 6311 C5
- 6320 E3
- 7300 C6
- 7310 D3
- 7320 E4
- 7330 G2
- 7331 H2
- 7332 H3
- 7340 H4
- 7341-A H7
- 7342 G10
- 7380 A7

BARE PCB
3139 243 30381 01
8239 210 91460

CL 16532162_015.eps
220102

V DC VOLTAGE MEASURED IN STOP_MODE
\$ VISHAY IR RECEIVER
@ ALTERNATE IR RECEIVER

Mother Board: Regulated Supply

A 4 Regulated Supply

A 4

A
B
C
D
E
F

1400 B1
1410 D1
2400 C4
2401 B4
2420 D6
2421 D8
2430 C7
2431 C8
2433 C6
2434 A6
2435 E2
2436 E5
2437 C6
2438 C7
2439 A6
2440 E3
3403 D2
3404 D3
3405 D4
3406 D4
3407 B4
3408 A5
3409 B5
3420 E5
3421 E6
3422 D7
3423 D8
3424 C2
3425 E4
3426 C3
3427 E5
4401 E6
4402 D9
4403 E9
4404 F9
4405 F9
6420 E7
7400 A3
7401 C3
7403 D4
7404 B3
7420 E5
7421 D7
7422 E5
7423 E3
9400 C7

From 0200 of PSU

From 0201 of PSU

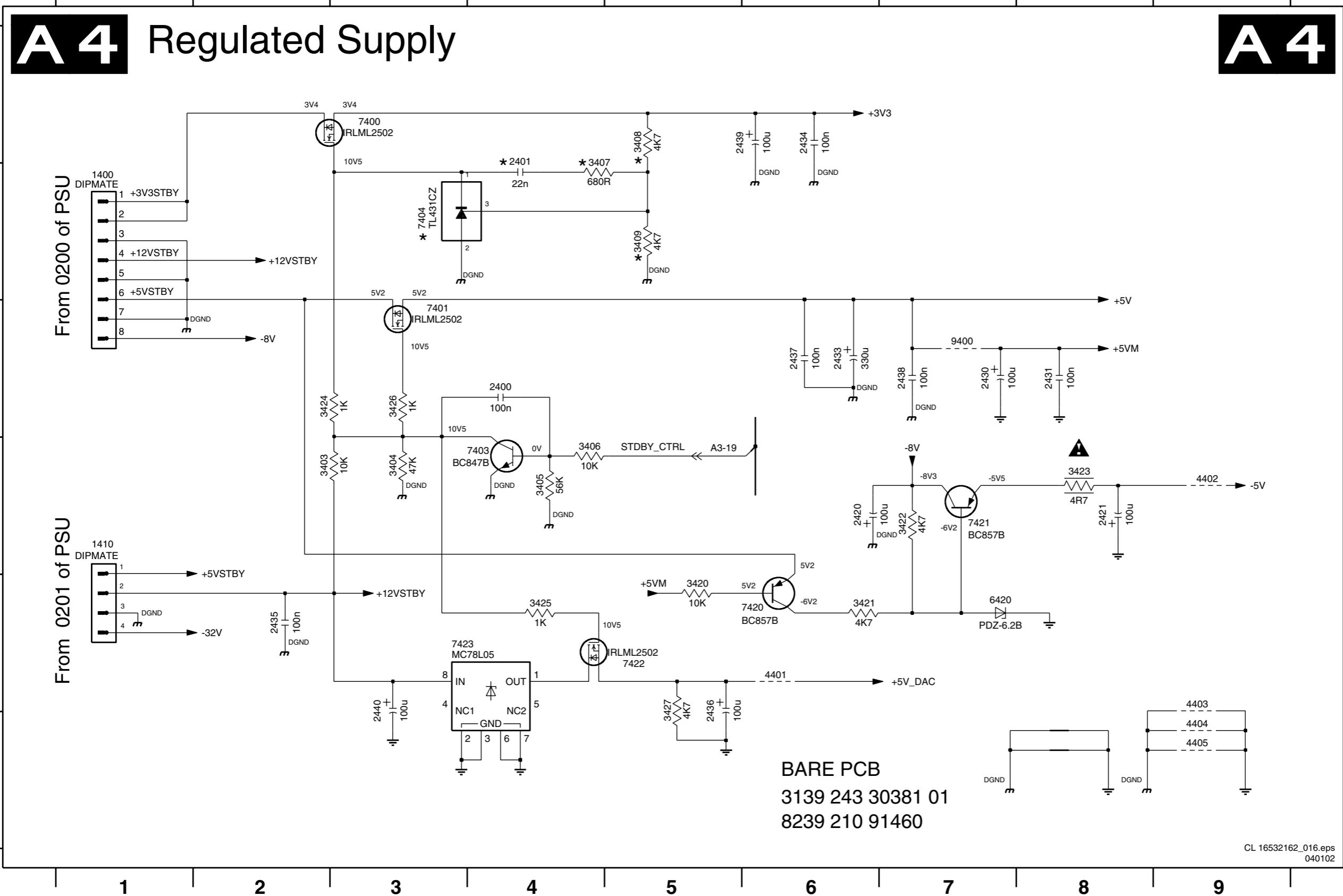

BARE PCB
3139 243 30381 01
8239 210 91460

CL 16532162_016.eps
040102

* Reserved Parts
V DC voltage measured in STOP_MODE

Layout Motherboard (Top View)

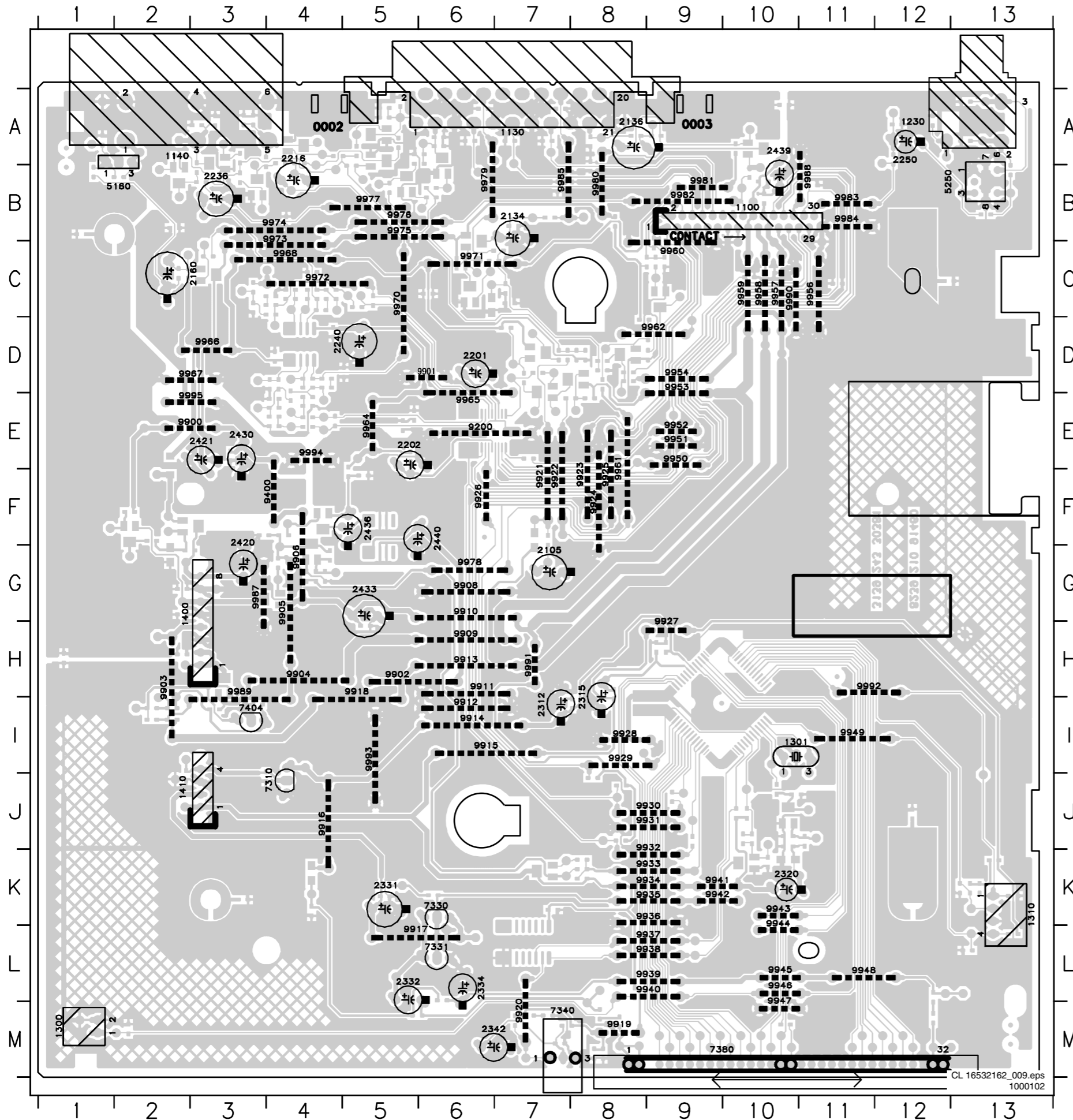

1100	B10	9933	K9
1130	A7	9934	K9
1140	A2	9935	K9
1230	A12	9936	K9
1300	M1	9937	L9
1301	I10	9938	L9
1310	K13	9939	L9
1400	G2	9940	L9
1410	J2	9941	K9
2105	G7	9942	K9
2134	B7	9943	K10
2136	A8	9944	K10
2160	C3	9945	L10
2201	D6	9946	L10
2202	E5	9947	L10
2216	A4	9948	L11
2236	B3	9949	I11
2240	D4	9950	E9
2250	A12	9951	E9
2312	I7	9952	E9
2315	H8	9953	D9
2320	K10	9954	D9
2331	K5	9956	C11
2332	L5	9957	C10
2334	L6	9958	C10
2420	F3	9959	C10
2421	E3	9960	C9
2430	E3	9961	E8
2433	G5	9962	D9
2436	F5	9964	E5
2439	A10	9965	E6
2440	F6	9966	D3
5160	B2	9967	D3
5250	B12	9968	C4
5400	E4	9969	C5
7310	J4	9970	C5
7330	K6	9971	C6
7331	L6	9972	C4
7340	M7	9973	B4
7380	M9	9974	B4
7404	I3	9975	B5
9200	E6	9976	B5
9400	F4	9977	B5
9900	E2	9978	G6
9901	D6	9979	B6
9902	H5	9980	B8
9903	H2	9981	B9
9904	H4	9982	B9
9905	G4	9983	B11
9906	G4	9984	B11
9908	G6	9985	B7
9909	H6	9987	G3
9910	G6	9988	B11
9911	H6	9989	H3
9912	I6	9990	C10
9913	H6	9991	H7
9914	I6	9992	H11
9915	I6	9993	I5
9916	J4		
9917	L5		
9918	H5		
9919	M6		
9920	M7		
9921	F7		
9922	F7		
9923	F8		
9924	F8		
9925	F8		
9926	F6		
9927	G9		
9928	I8		
9929	I8		
9930	J9		
9931	J9		
9932	J9		

Layout Motherboard (Overview Bottom View)

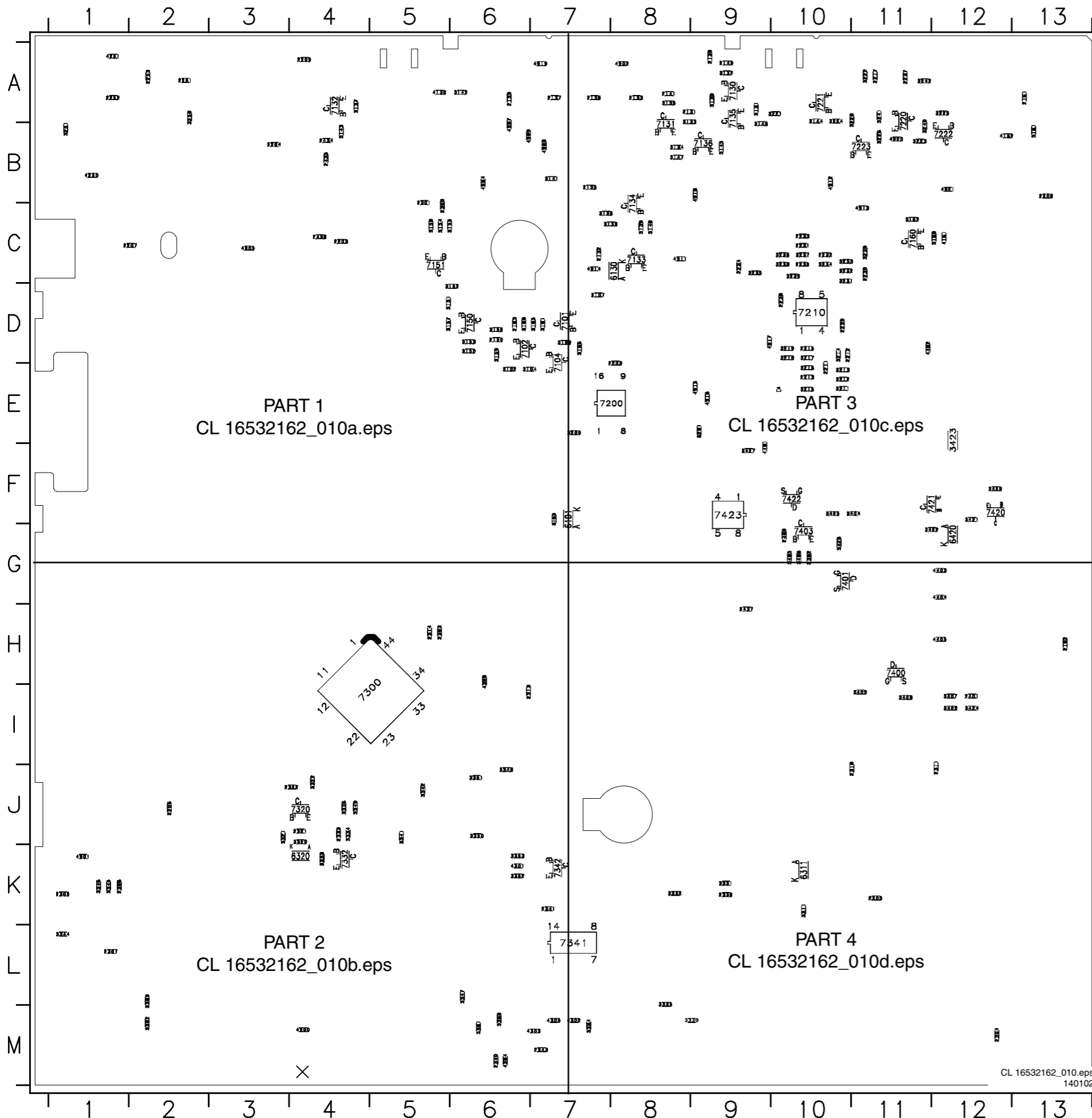

2102	H13	3157	D5	4902	B9
2103	D6	3158	C5	4904	B6
2130	A9	3159	D6	4905	C3
2131	A8	3160	C12	4907	B6
2132	C7	3161	B13	4908	B7
2133	A8	3162	C11	4909	B6
2135	B7	3200	E7	4911	C8
2137	A7	3201	E9	4912	B10
2138	A7	3210	E10	4913	C11
2139	A6	3211	E10	4914	C7
2140	A9	3212	E10	4915	E9
2141	A8	3213	E10	4916	E9
2150	D6	3214	D10	4917	D9
2161	A13	3215	E10	4918	B9
2200	D8	3216	E10	6101	F7
2203	C4	3217	D10	6130	C8
2204	B3	3218	D10	6311	K10
2205	K11	3219	D10	6320	K4
2206	J2	3220	A11	6420	G12
2207	C2	3221	A10	7101	D7
2208	B13	3222	A11	7102	D6
2209	A4	3223	B11	7104	D7
2210	E10	3224	A10	7130	A9
2211	E10	3225	A12	7131	B8
2212	D10	3226	B11	7132	A4
2213	E10	3230	C11	7133	C8
2214	E10	3231	C10	7134	C8
2215	D10	3232	C10	7135	A9
2217	A11	3233	C10	7136	B9
2230	C11	3234	C10	7150	D6
2231	C10	3235	C9	7151	C5
2232	C10	3236	C10	7160	C11
2233	C10	3237	C10	7200	E8
2234	C9	3238	C10	7210	D10
2235	C10	3239	C10	7220	A11
2237	A11	3240	B11	7221	A10
2238	D10	3241	A11	7222	B12
2239	D10	3242	A11	7223	B11
2251	A2	3250	A2	7300	I5
2252	A1	3251	B1	7320	J4
2253	A2	3311	K10	7332	K4
2300	C5	3320	J4	7341	L7
2301	B5	3321	J3	7342	K7
2302	G10	3322	J4	7400	H11
2303	H5	3330	M8	7401	G10
2304	M12	3331	K9	7403	G10
2305	K1	3332	K8	7420	F12
2306	K1	3333	K4	7421	F11
2307	L1	3334	J4	7422	F10
2310	J11	3335	M8	7423	F9
2311	J12	3336	J4		
2313	I6	3341	J5		
2314	H5	3342	J5		
2321	J4	3344	L1		
2322	J4	3345	K1		
2330	K9	3346	K1		
2333	J4	3347	L6		
2340	M7	3348	J6		
2341	K7	3349	J4		
2400	G10	3350	J6		
2401	I2	3351	J6		
2431	E11	3352	K6		
2434	B4	3353	K6		
2435	B4	3380	M6		
2437	H9	3381	M6		
2438	C4	3382	M2		
3101	D7	3383	L2		
3102	E6	3403	I12		
3103	F7	3404	F11		
3104	E6	3405	G10		
3105	D7	3406	G10		
3106	D7	3407	I12		
3107	D7	3408	I11		
3108	D6	3409	I11		
3109	D7	3420	F12		
3130	A9	3421	F12		
3131	A9	3422	G12		
3132	A9	3423	E12		
3133	A8	3424	I12		
3134	B8	3425	F10		
3135	A8	3426	G10		
3136	C7	3427	F9		
3137	A4	4130	A5		
3138	C8	4161	C12		
3139	C8	4162	B12		
3140	C8	4250	B1		
3141	B7	4251	A1		
3142	A6	4300	H6		
3143	B4	4301	K6		
3144	A10	4302	M7		
3145	B9	4303	M7		
3146	B9	4304	M7		
3147	B8	4305	M6		
3150	D6	4401	F9		
3151	D5	4402	D12		
3152	D6	4403	G12		
3153	D6	4404	G12		
3154	C5	4405	H12		
3155	C5	4900	M4		
3156	D6	4901	K1		

Layout Motherboard (Part 1 Bottom View)

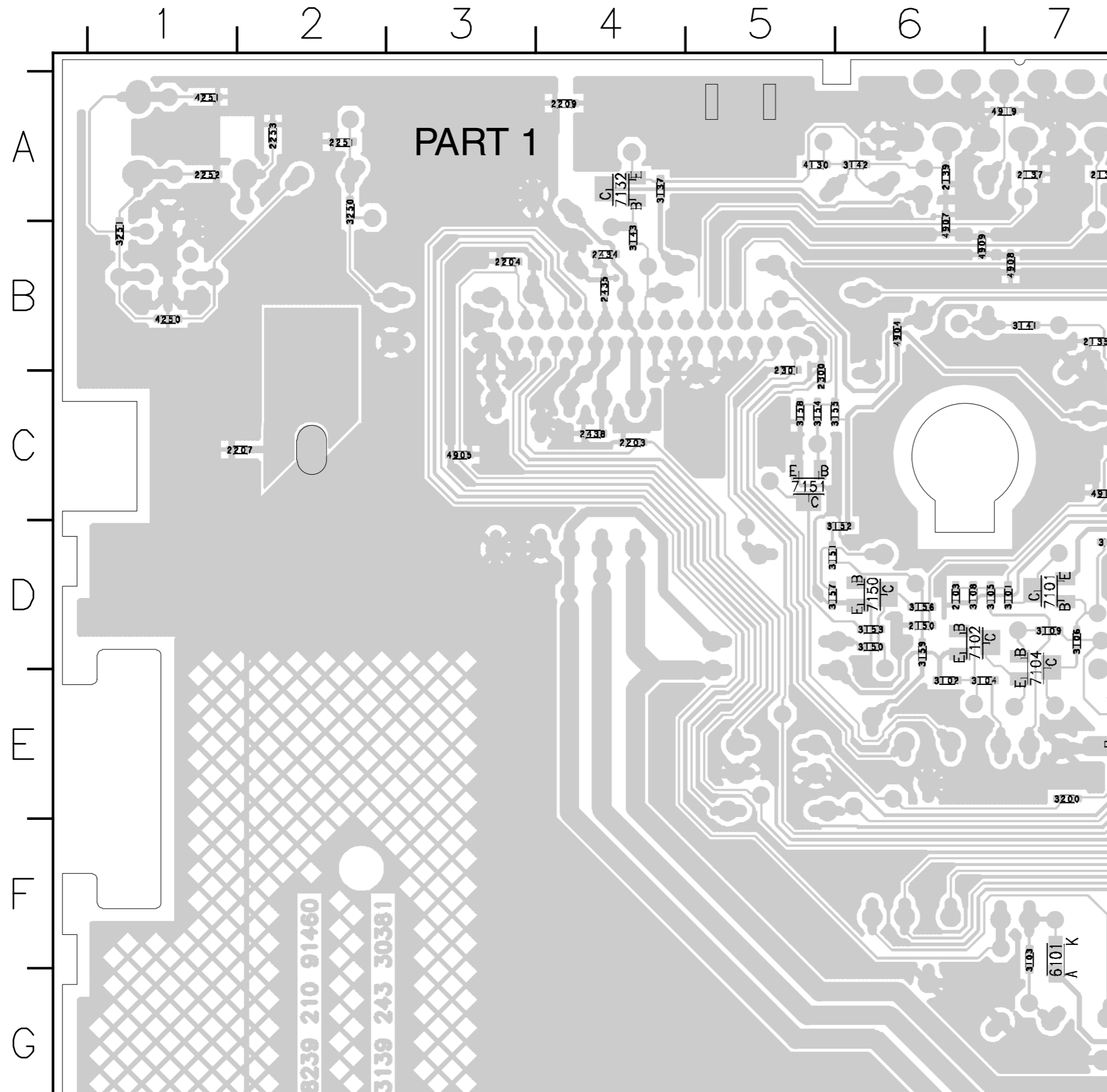

Layout Motherboard (Part 2 Bottom View)

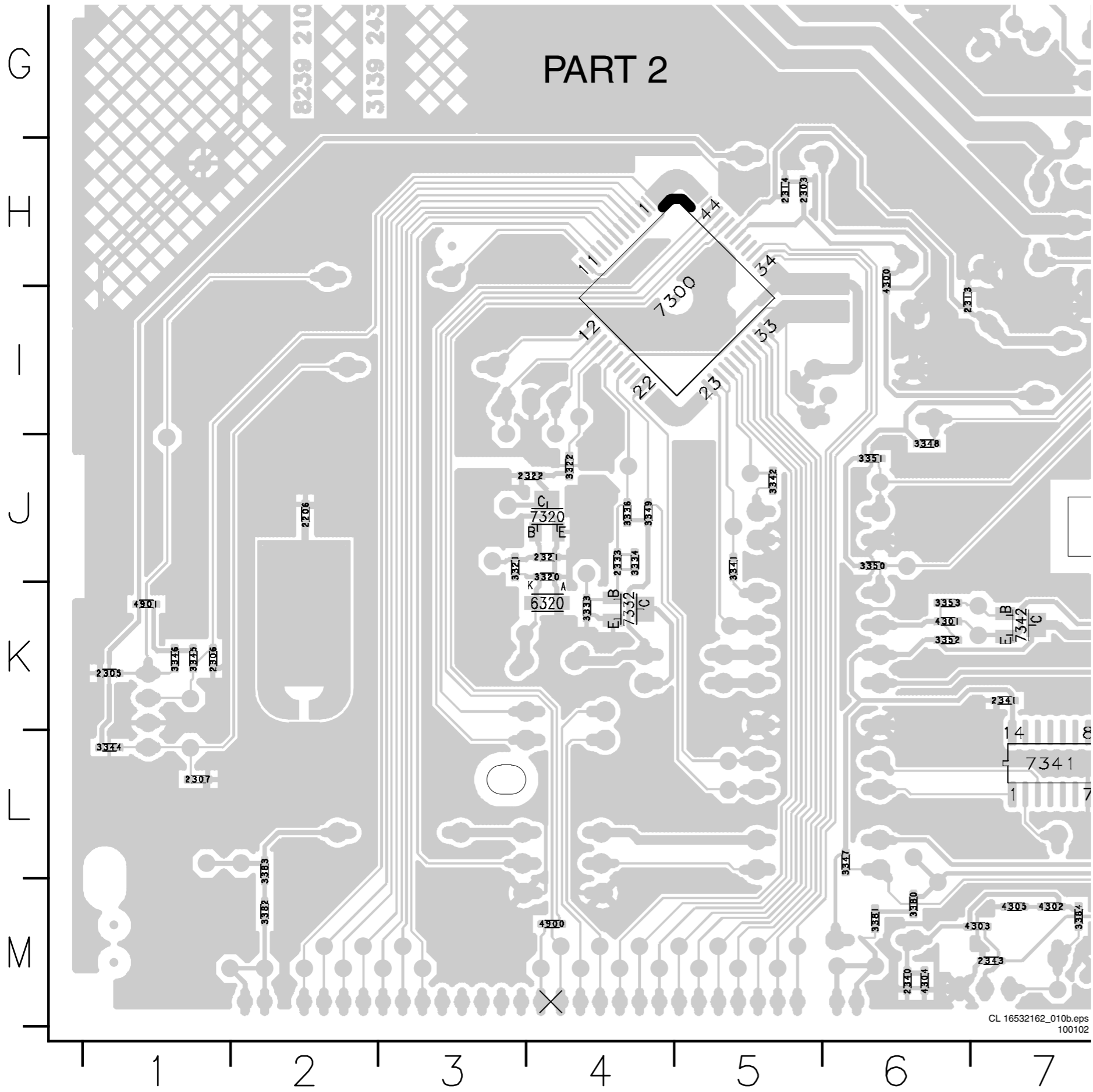

Layout Motherboard (Part 3 Bottom View)

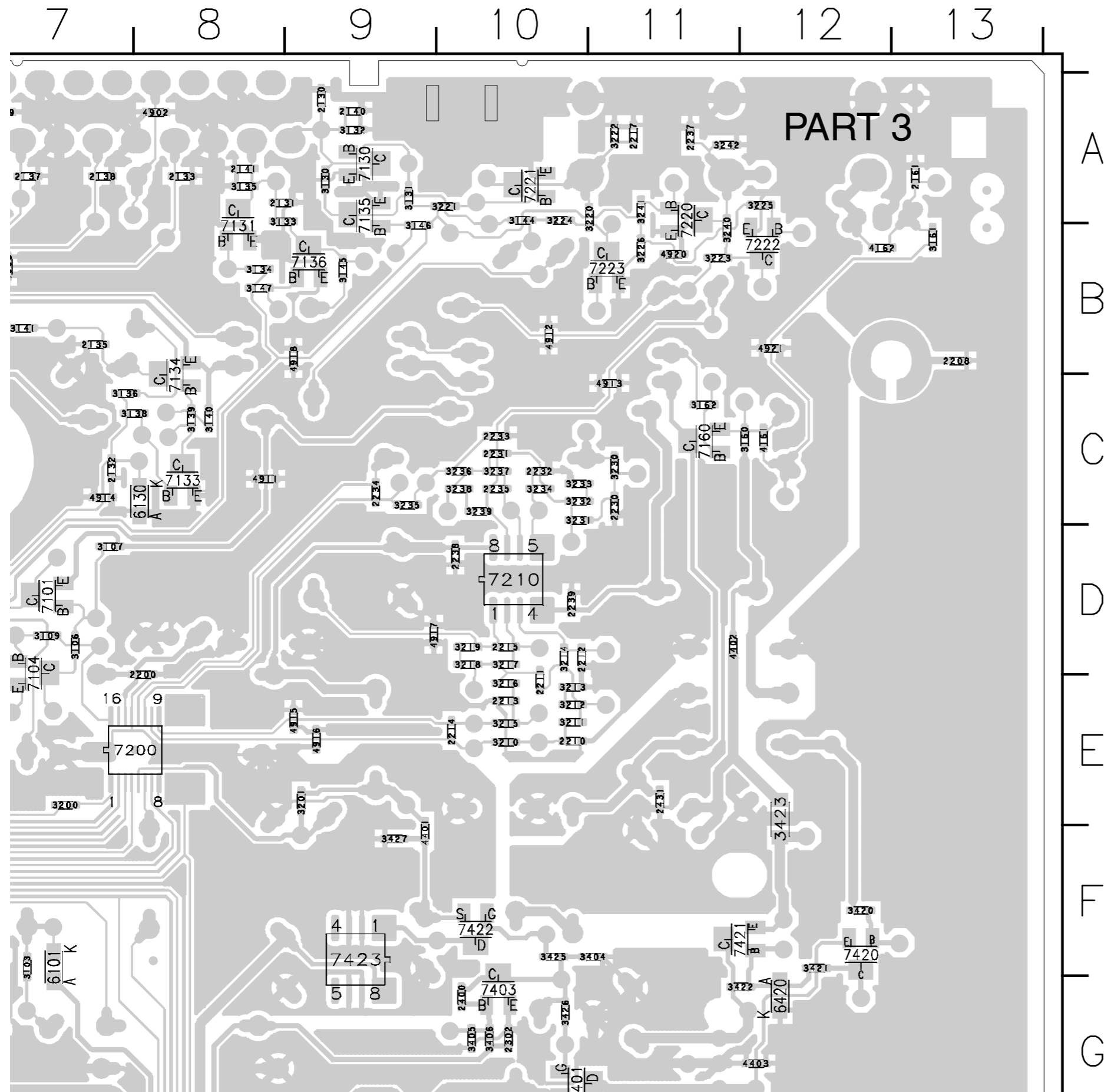

Layout Motherboard (Part 4 Bottom View)

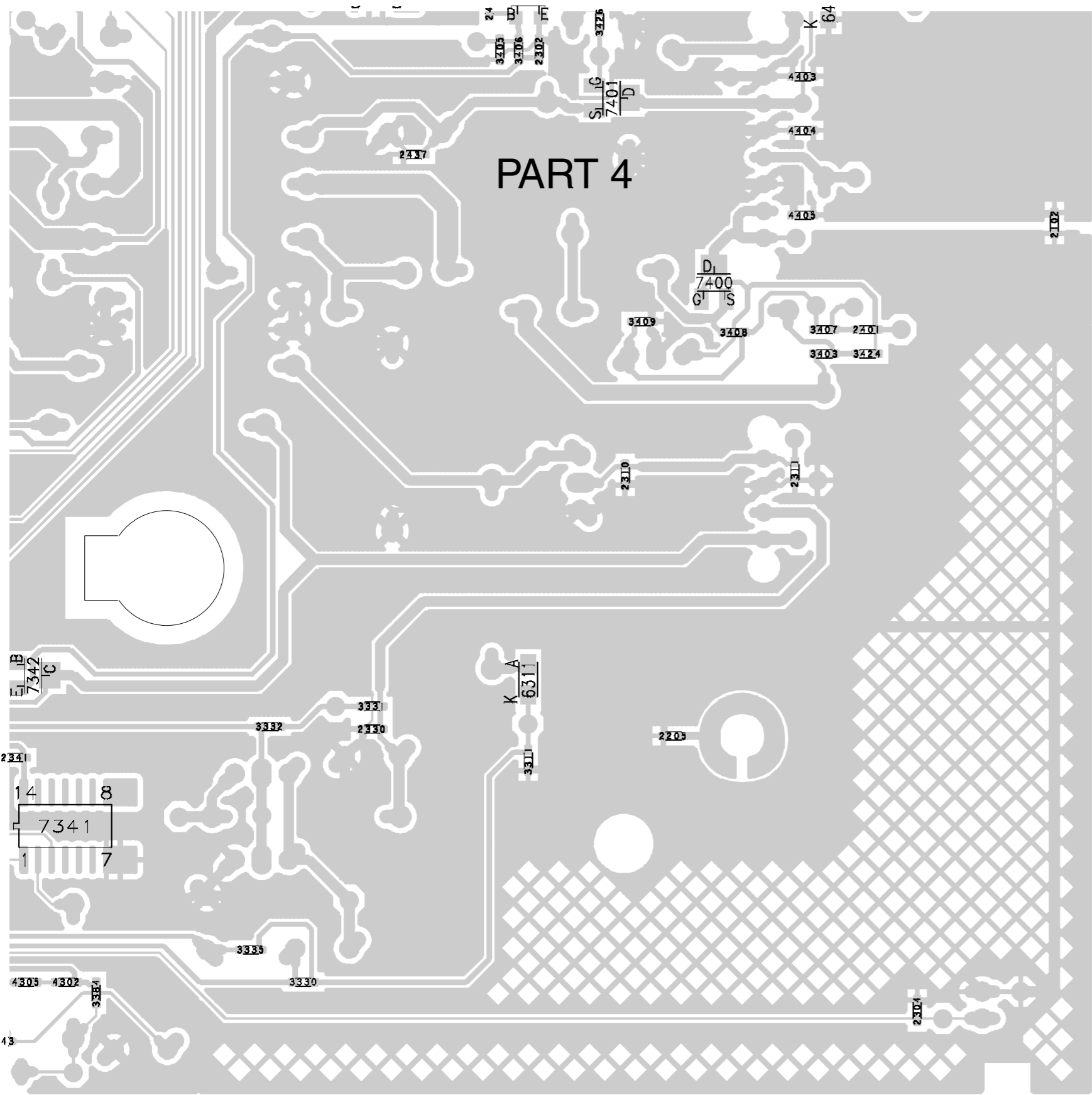

G
H
I
J
K
L
M

7 8 9 10 11 12 13

Layout Motherboard (Testpoints Bottom View)

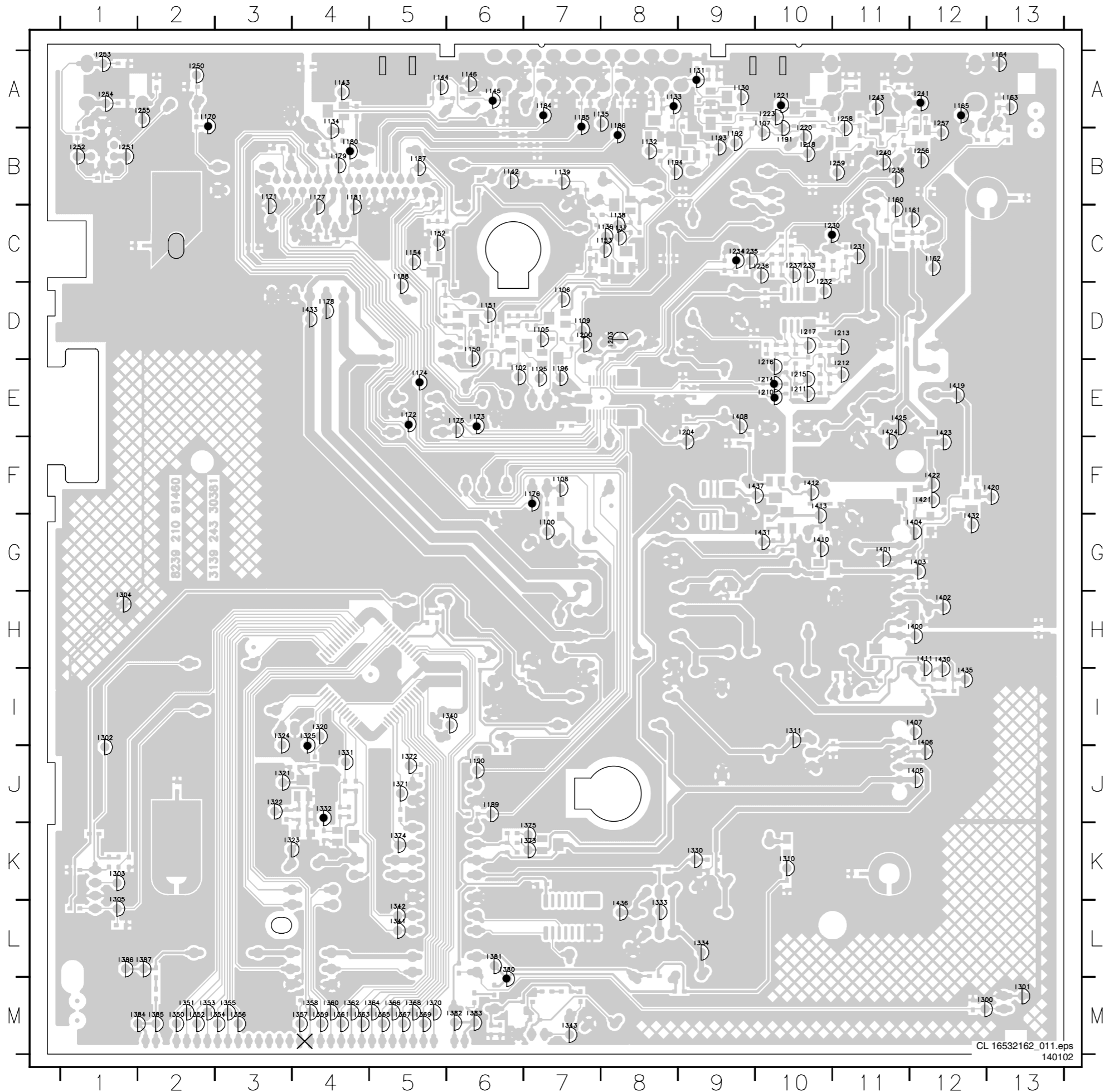

I100	G7	I214	E10	I363	M4
I102	E6	I215	E10	I364	M5
I105	D7	I216	E10	I365	M5
I106	D7	I217	D10	I366	M5
I107	A10	I218	B10	I367	M5
I108	F7	I220	B10	I368	M5
I109	D7	I221	A10	I369	M5
I130	A9	I223	A10	I370	M5
I131	A9	I230	C10	I371	J5
I132	B8	I231	C11	I372	J5
I133	A8	I232	C10	I373	K7
I133	A9	I232	D11	I374	K5
I134	B4	I233	D10	I375	K7
I135	A8	I234	C9	I380	M6
I136	C8	I235	C9	I381	L6
I137	C8	I236	D9	I382	M6
I138	C8	I237	D10	I383	M6
I139	B7	I238	B11	I384	M2
I142	B6	I240	B11	I385	M2
I143	A4	I241	A12	I386	L1
I144	A6	I243	A11	I387	L2
I145	A6	I250	A2	I400	H12
I146	A6	I251	B1	I401	G11
I150	E6	I252	B1	I402	H12
I151	D6	I253	A1	I403	G12
I152	C5	I254	A1	I404	G12
I153	C8	I255	B2	I405	J12
I154	C5	I256	B12	I406	I12
I160	B11	I257	B12	I407	I12
I161	C12	I258	A11	I408	E9
I162	C12	I259	B11	I410	G10
I163	A13	I300	M12	I411	H12
I164	A13	I301	M13	I412	F10
I165	A12	I302	I1	I413	G10
I170	B3	I302	J1	I419	E12
I171	B3	I303	K1	I420	F13
I172	E5	I304	H1	I421	F12
I173	E6	I305	L1	I422	F12
I174	E5	I310	K10	I423	E12
I175	E6	I311	I10	I424	F11
I176	F7	I320	I4	I425	E11
I177	B4	I321	J3	I430	H12
I178	D4	I322	J3	I431	G10
I179	B4	I323	K3	I432	G12
I180	B5	I324	J3	I433	D4
I181	B4	I325	J4	I435	I12
I184	A7	I330	K9	I436	L8
I185	A7	I331	J4	I437	F10
I186	A8	I332	J4		
I186	B8	I333	L8		
I187	B5	I334	L9		
I188	C5	I340	I6		
I188	D5	I341	L5		
I189	J6	I342	L5		
I190	J6	I343	M7		
I191	B10	I350	M2		
I192	B9	I351	M2		
I193	B9	I352	M2		
I194	B9	I353	M2		
I195	E7	I354	M3		
I196	E7	I355	M3		
I200	D7	I356	M3		
I203	D8	I357	M4		
I204	F9	I358	M4		
I210	E10	I359	M4		
I211	E10	I360	M4		
I212	E11	I361	M4		
I213	D11	I362	M4		

Front Control Panel and Layout

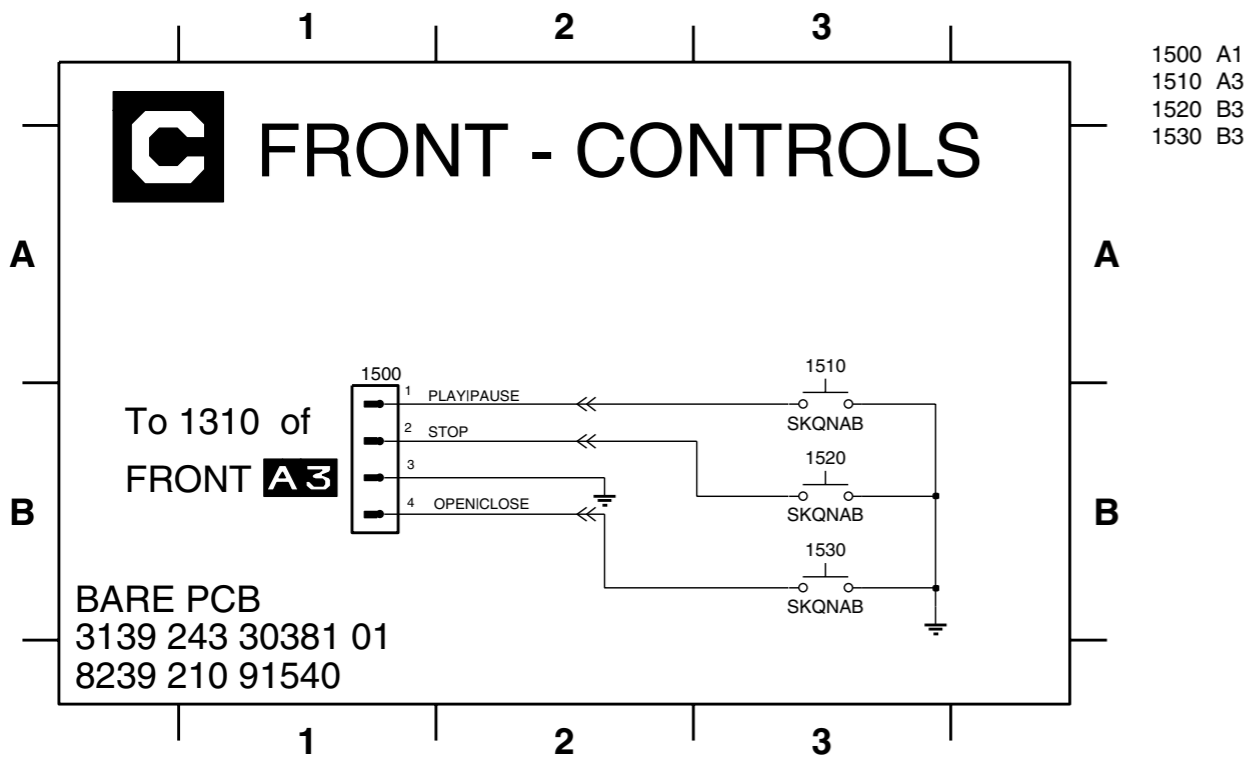

Front Standby Panel and Layout

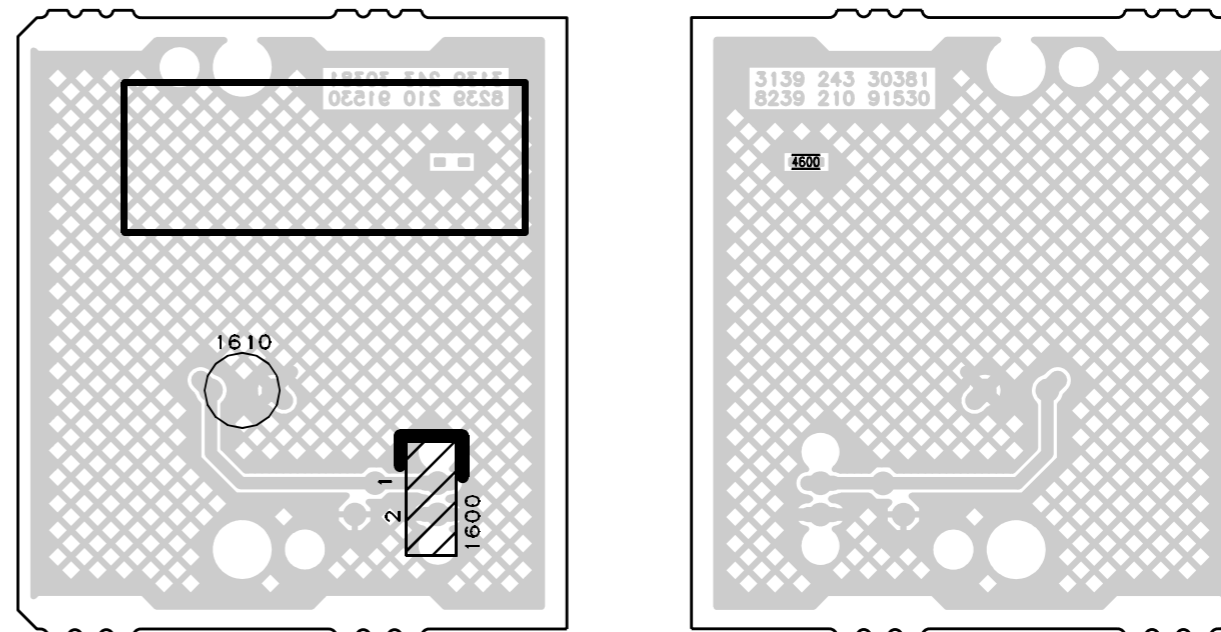
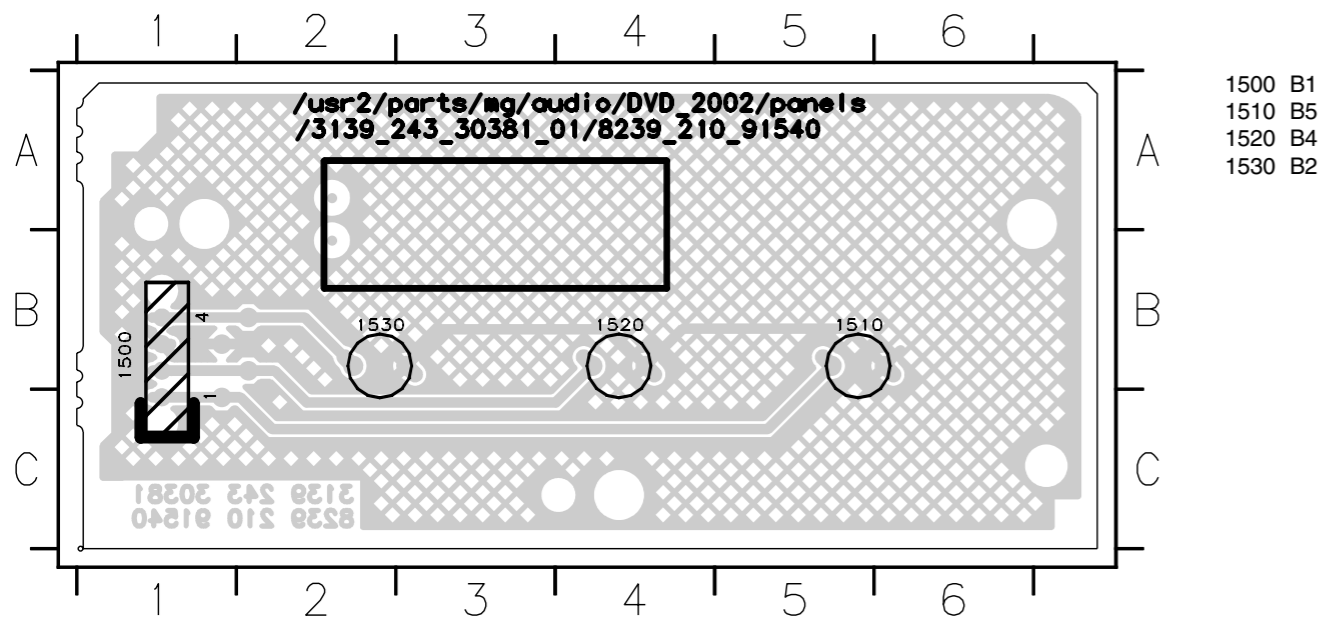
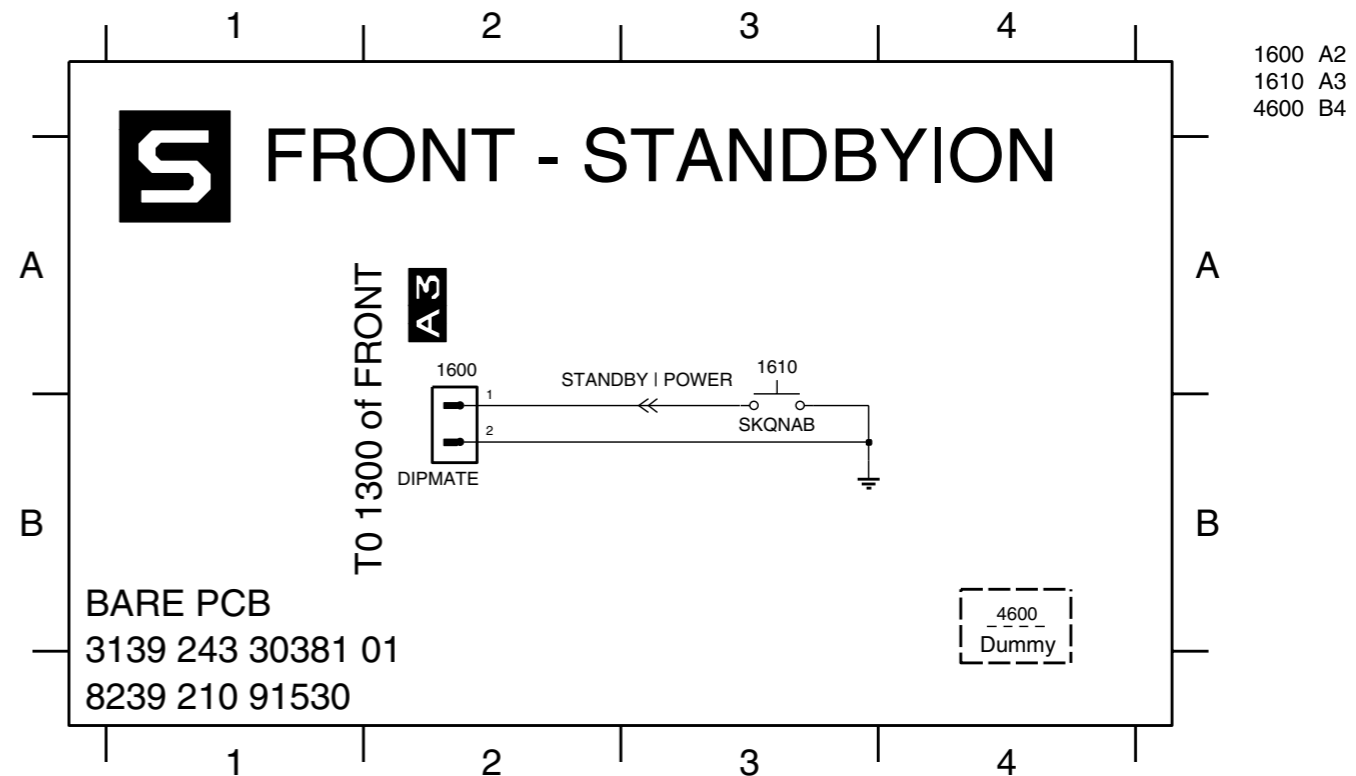

8. Alignments

Not applicable.

9. Circuit Descriptions, List of Abbreviations, and IC Data

Index of this chapter:

1. Introduction
2. Power Supply
3. Loader/Mono Board
4. Mother Board
5. Abbreviations
6. IC Data

Notes:

- Figures can deviate slightly from the actual situation, due to different set executions.
- For a good understanding of the following circuit descriptions, please use the diagrams in chapter 6 and 7.

9.1 Introduction

The DVD6xx range (620, 623, and 633) is a fourth generation DVD players. Some of their features are:

- MP3 playback.
- 3D Sound.
- Auto power off (after 15 min.).
- Build in MPEG2, MP3, and AC-3 decoder.
- CD-R(W) compatible.
- DVD+R(W) compatible.
- RGB video output on SCART.

Panel Overview

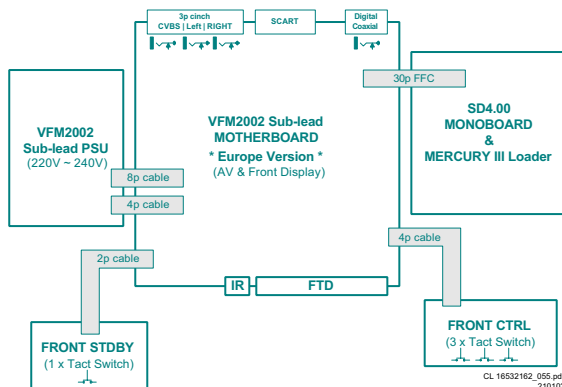

Figure 9-1

The DVD620 uses the new SD4.0 loader module. It also has a new mother board (one panel for audio, video, and display) and a dedicated power supply (based on the Step2001 type).

This SD4.0 mono board has the same service (ComPair) connector as in previous versions.

Flashing of the application-SW is not possible via the ComPair cable, only with a CD-R disc.

For sets with mask-ROM software, replace it with a programmed Flash (available via your Philips Service organisation).

9.2 Power Supply

9.2.1 Introduction

The supply is a Switching Mode Power Supply (SMPS), which uses the control IC TY720xx to produce pulses to drive the power 'switch' (MOSFET). The TY720xx (item 7130) is a high performance, current mode controller for DC-to-DC converter applications.

The operation frequency varies with the circuit load. When the output power demand decreases, the switching frequency raises, with a maximum frequency of 125 kHz (determined by C2107 at pin 5). At this point, the internal VCO takes over and starts to decrease the switching frequency.

This has some benefits compared to a 'fixed frequency' flyback converter. The efficiency is better, which results in a lower power consumption.

9.2.2 Output Voltages

PSU Connection

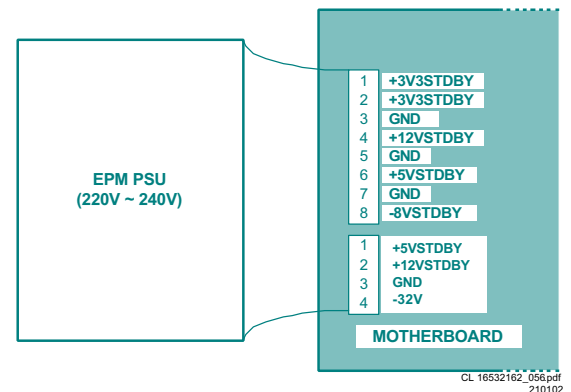

Figure 9-2

The following voltages are connected to the motherboard via connectors 1400 and 1410:

- +12VSTBY, 470 mA.
- +5VSTBY, 400 mA.
- +3V3STBY, 1200 mA.
- -8V, 30 mA.
- -32V, 16 mA.

The +12VSTBY, on pin 2 of connector 1410, is further divided into the following voltage:

- +5V_DAC (via voltage regulator 7423), supply to audio DAC, and OpAmp filter.

The +5VSTBY, on pin 6 of connector 1400, is further divided into the following voltages:

- +5V, supply to SD4.0 mono board.
- +5VM, supply for analogue circuitry.

The suffix 'STBY', indicates that the supply is not switched 'off' during Standby Mode. Power switching is done **on the motherboard** with the STBY_CTRL signal from the slave processor.

Power Switching

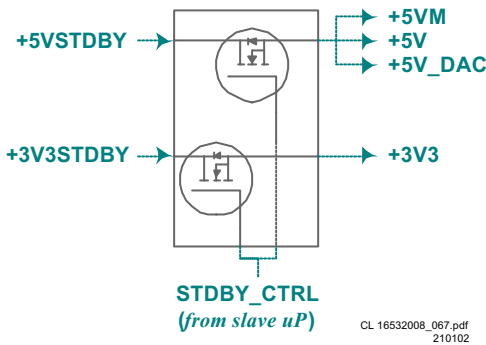

Figure 9-3

The derived voltages +3V3, +5V, and +5V_DAC are switched 'off' during Standby Mode with a MOSFET (see items 7400, 7401, and 7422 on diagram A4).

The -8V is regulated to -5.5V via transistor 7421 and zenerdiode 6420, and is switched 'off', with transistor 7420, during Standby Mode.

The -32V is not switched 'off' during Standby Mode.

9.2.3 Operation

Mains Input Circuit

The bridge rectifier (D6110-D6113), direct after the mains filter 5115, rectifies the mains voltage, after which C2116 smoothens it. The DC voltage across this capacitor is the DC input voltage (HV= approximately 300 V), to pin 9 of transformer T5190 and pin 1 of IC7130.

Start-up Circuitry

The rectified voltage from the bridge rectifier is connected to pin 1 via L5130. It will charge the VCC capacitor (C2131). When this voltage, (at pin 13 of 7130), reaches the start-up threshold of min 15 V, the control circuit starts to operate. After start-up, IC 7130 requires a sinking current, which the start-up circuitry cannot deliver. Therefore, a take-over circuitry (a coupled winding of transformer L5190) is present. The voltage here will take over the supply voltage at pin 13 of the IC. If the take-over circuit does not function, the IC will switch 'off' again at the minimal operating voltage of +8 V. The whole operation cycle will repeat itself with audible hiccup sound if take-over is not present.

Secondary Voltage Sensing

The secondary voltage regulating circuit comprises of opto-coupler 7190 (which isolates the error signal from the control IC on the primary side), and a reference component 7290 (TL431) with the following functions:

- A very stable and accurate reference diode.
- A high gain amplifier.

TL431

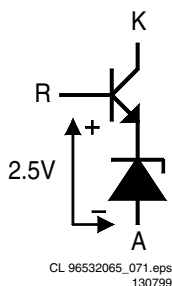

Figure 9-4

When the output voltage increases (due to a reduction in the load), the voltage across R3290+R3291 increases to above the internal reference voltage of 2.5 V. Item 7290 will conduct and the current through the opto-coupler will increase. This results in an increase of the voltage at pin 4 of 7130, which will reduce the 'on' time of FET 7125. In the event of an output voltage decrease (due to an increase in the load), the control circuit will operate in the opposite way.

Primary Current Sensing

The current through FET 7125 will result in a voltage drop across R3120/21/22 (RSENSE). This line goes to pin 11 of 7130, which is the current sense input. The higher the input voltage, the more the primary current is limited. In this way, the maximum output power of the power supply is limited.

Under-voltage Protection

If the supply voltage at pin 13 drops below 7.2 V (typical), e.g. due to a shorted secondary voltage or excessive load, the drive pulse at pin 12 is disabled and the controller will switch 'off'.

Over-voltage Protection

An internal over-voltage protection circuitry continuously monitors the VCC pin. If, after start-up, this voltage exceeds 40 V, the internal latch circuit is triggered, the output buffer is disabled, and the SMPS goes into over-voltage protection. Now a complete restart sequence is required.

Note: If the event of the over-voltage situation remains present, the SMPS will go in sequence of protection, start-up, protection and the cycle repeats. This effect is highly audible.

9.3 Loader/Monoboard

For an extensive circuit description of the SD4.0 Loader/Monoboard, see the **SD4.0 Service Manual 3122 785 12230**.

9.4 Mother Board (Diagram A)

9.4.1 Introduction

In this new DVD player generation all separate circuits, as used in the former generation (like the SCART, A/V, DTS, and Display boards), are combined on one motherboard. The different parts are described below.

9.4.2 Control

The most important component on this board is the (slave) microprocessor (item 7300, Toshiba TMP47C416). It runs on an 8MHz system clock generated with a ceramic resonator. After the RESET pulse (active LOW), the STB_CTRL line (pin 23, item 7300) will release the reset of the host uP (on the mono board) via the switched 3V3 supply (see circuit around item 7605 on mono board).

Other slave processor functions are:

- Generation of a scanning grid for the keys.
- Generation of the display grid and segment scanning.
- Generation of a square signal to generate the filament voltage for FTD display.
- Input for RC5/6 remote control protocol. The logic is HIGH > 4.5V and LOW < 0.3V.

Slave Processor Interface

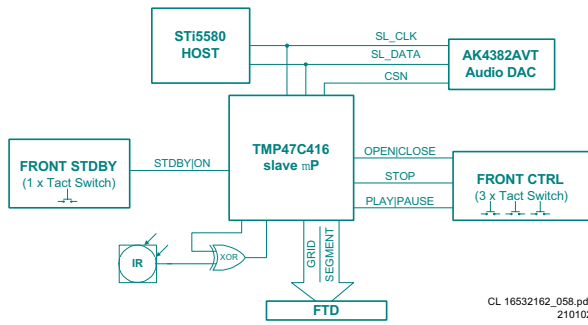

Figure 9-5

The block diagram above, illustrates the interfaces of the slave uP. The start-up sequence is as follows:

1. The required IC voltage is the +5VSTBY, which is present during Standby Mode.
2. When the RESET circuit (7320) is triggered by the +5VSTBY, the slave uP initialises.
3. This will set the STDBY_CTRL signal to LOW, which will switch on the +3V3 and +5V.
4. Once these voltages are provided, the host uP (STi5580 on the SD4.0 mono board) will reset.
5. Now, the host uP will initialise, and indicate the slave uP to activate the Standby Mode (STBY_CTRL) signal.
6. The player wakes up from the Standby Mode when any button is pressed on the front panel, or when the 'Power' button is pressed on the Remote Control.

Note: The slave uP will not reset successfully if the 8MHz clock oscillator has not stabilised (check on pin 14 of item 7300).

Video Path

The video output from the STi5580 is RGB and CVBS. These signals enter the motherboard via connector 1100. Buffering is already done on the SD4.0 mono board, therefore the RGB signals go directly to the SCART connector. The CVBS signal however, first goes through a transistor (item 7132) for impedance matching.

The '0|6|12' switch signal on pin 10 of the SCART connector, depends on the logic state of two other signals: SCART0 from the host uP and STBY_CTRL from the slave uP. This is done according to the following table:

Status Truth Table

SCART_0	STBY_CTRL	0 6 12	Function
0	0	12V	4:3 aspect ratio DVD
0	1	0V	TV display
1	0	6V	16:9 aspect ratio DVD
1	1	0V	TV display

Figure 9-6

Audio Path

Audio DAC circuitry

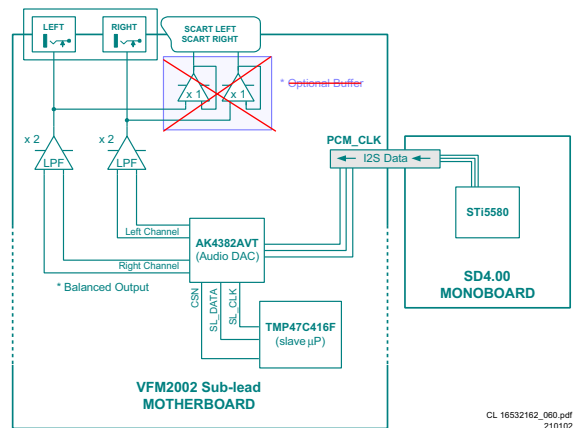

Figure 9-7

The STi5580 supplies I2S data and PCM_CLK master clock to the new audio DAC (item 7200, AK4382AVT).

The decoded analogue output of both left and right channel is balanced. These are filtered (3-pole LPF) and amplified with OpAmp LM833 (item 7210). The gain of this OpAmp is two times.

There is only one stereo output from the motherboard and a coaxial output.

The audio DAC accepts only +5V inputs with +3V3 tolerance. During STDBY mode, there will be no power to the audio DAC. The registers of the audio DAC are in their default values each time the power to the IC is cut-off. The slave uP is required to program the DAC each time after exiting from STDBY mode. This requires three signal lines.

- CSN - Chip Select Pin.
 - CCLK - Control Clk Input Pin.
 - CDTI - Control Data Input Pin in Serial Mode.
- CCLK and CDTI are also used as SIO_CLK and SIO_DATA respectively, for communication between the slave uP and STi5580. Both signal lines require pull-up resistors to +5VSTDBY and are located in the Motherboard. Buffers for these two signals are located in the SD4.00 Monoboard. The host uP (STi5580) will indicate the slave uP when to program the audio DAC after waking up from STDBY mode.

The audio MUTE signal depends on the logic state of two other signals:

- KILL: This signal comes from the host processor (STi5580) and is meant to mute the outputs during switch on/off.
- KILL_LR: This is a signal from the audio DAC, when it receives no input for a certain time (8192 LRCK cycles). It can be tested in STOP, PAUSE and during track changes. The logic level for the MUTE signal is -3V < LOW < 0V and 0V < HIGH < +3V.

Mute Truth Table

KILL	KILL_LR	MUTE	Function
0	0	0	Output is not muted.
0	1	1	Output is muted.
1	0	1	Output is muted.
1	1	1	Output is muted.

Figure 9-8

FTD Display

The slave uP drives the 7-segment FTD. It provides a negative DC switching drive voltage. As the display consists of seven segments, there are seven grid signals (G1-G7) controlling each respective grid.

The slave processor has an internal square signal generator (42 kHz), to generate the AC filament voltage. TS7330 and 7331 amplify the square signal before it is applied to the display (VAC= VFIL_1 - VFIL_2, VRMS≈ 2.4V). The necessary power supply of -18V is derived (via zener diode 6311) from the -24V of voltage regulator 7310.

9.5 User Interface

The user interface consists of two different panels with only some tact-switches mounted on them. When one of these switches is pressed, the signal at the scanning pins (slave uP pins 9 to 12) goes from +5 V to 0 V.

9.6 Abbreviation list

ADC	Analogue to Digital Converter
AM	Amplitude Modulation
AV	External Audio Video
BE	Basic Engine
ComPair	Computer aided rePair
CD-DA	CD Digital Audio
CS	Chip Select
CVBS	Composite Video Blanking and Synchronisation
DAC	Digital to Analogue Converter
DFU	Direction For Use: description for the end user
DNR	Dynamic Noise Reduction
DRAM	Dynamic RAM
DSD	Direct Stream Digital
DSP	Digital Signal Processing
DTS	Digital Theatre Sound
DVD	Digital Versatile Disc
EMI	External Memory Interface (ST155xx)
EXT	External (source), entering the set via SCART or Cinch
FFC	Flat Foil Cable
FLASH	Flash memory
FM	Frequency Modulation
FTD	Fluorescent Tube Display
HP	Headphone
HPF	High Pass Filter
HW	Hardware
I2C	Integrated IC bus
I2S	Integrated IC Sound bus
IC	Integrated Circuit
IF	Intermediate Frequency
IR	Infra Red
IRQ	Interrupt Request
LED	Light Emitting Diode
LPCM	Linear Pulse Code Modulation
LPF	Low Pass Filter
LRCLK	Left/Right clock
LVTTTL	Low Voltage Transistor Transistor Logic (3.3V logic)
MPEG	Motion Pictures Experts Group
NC	Not Connected
NTSC	National Television Standard Committee. Colour system mainly used in North America and Japan. Colour carrier NTSC M/N = 3.579545 MHz, NTSC 4.43 = 4.433619 MHz (this is a VCR norm, it is not transmitted off-air)
NVM	Non Volatile Memory: IC containing TV related data e.g. alignments
OC	Open Circuit
OSD	On Screen Display
P50	Project 50 or Easy Link
PAL	Phase Alternating Line. Colour system mainly used in West Europe (colour carrier = 4.433619 MHz) and South

PCB	Printed Circuit Board (see PWB)
PCM	Pulse Code Modulation
PCM_CLK	Audio system clock for DAC
PCM_OUTx	Audio serial output data
PSU	Power Supply Unit
PWB	Printed Wiring Board (see PCB)
RAM	Random Access Memory
RC	Remote Control handset
RC5/6	Remote Control system 5/6, signal from/to the remote control receiver
RGB	Red, Green and Blue colour space
ROM	Read Only Memory
SCART	Syndicat des Constructeurs d'Appareils Radiorecepteurs et Televisieurs
SCL	Serial Clock I2C
SCLK	Audio serial bit clock
SDA	Serial Data I2C
SDRAM	Synchronous DRAM
S/PDIF	Sony Philips Digital InterFace
SRAM	Static RAM
STBY	Standby
SVCD	Super Video CD
SVHS	Super Video Home System
SW	Software
THD	Total Harmonic Distortion
TTL	Transistor Transistor Logic (5V logic)
TXT	Teletext
uP	Microprocessor
VCD	Video CD
Y/C	Luminance (Y) and Chrominance (C) signal
YUV	Component video
0/6/12	SCART switch control signal on A/V board. 0 = loop through (AUX to TV), 6 = play 16:9 format, 12 = play 4:3 format

9.7 IC Data

In this paragraph, the internal block diagrams and pinning are given of ICs that are drawn as 'black box' in the electrical diagrams (with the exception of 'memory' and 'logic' ICs).

9.7.1 Diagram Power Supply

TY72011P2 Block Diagram (item 7130)

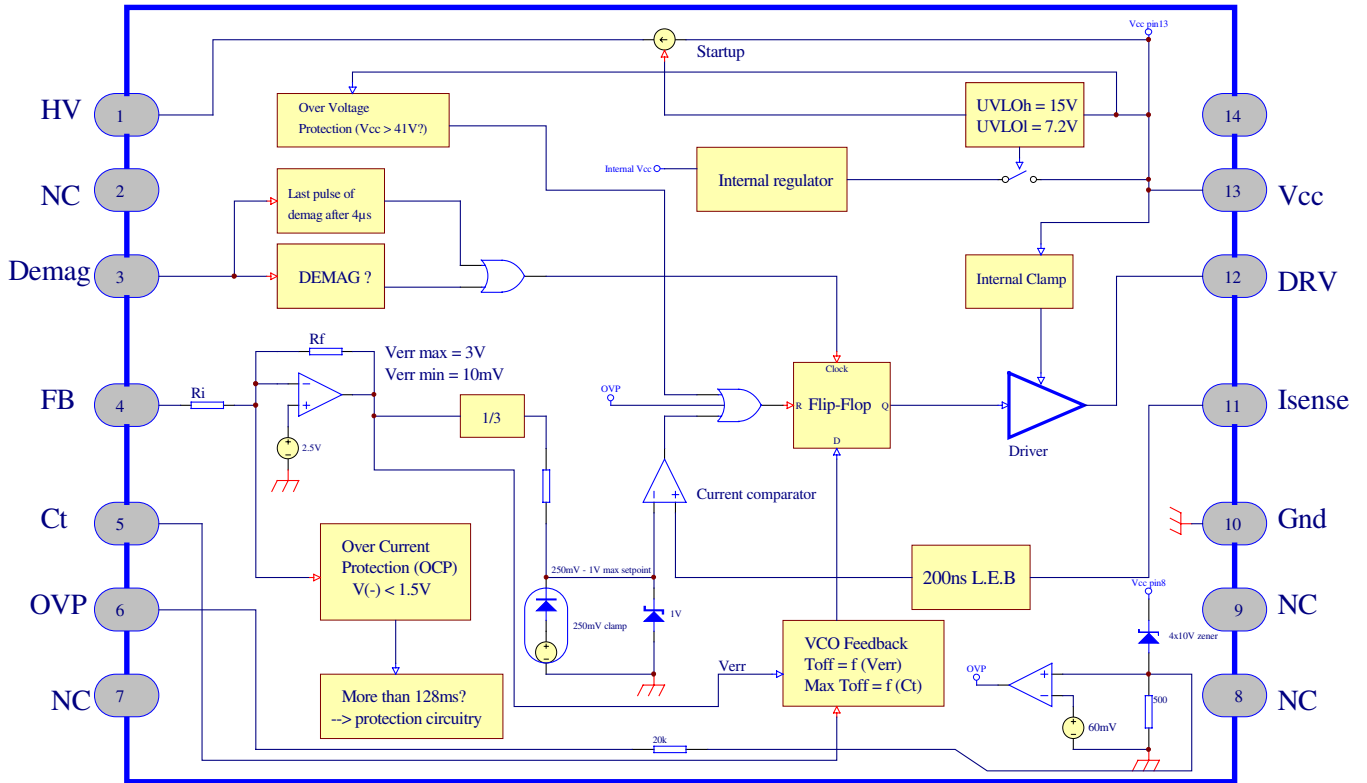

Figure 9-9

TY72011P2 Pinning (item 7130)

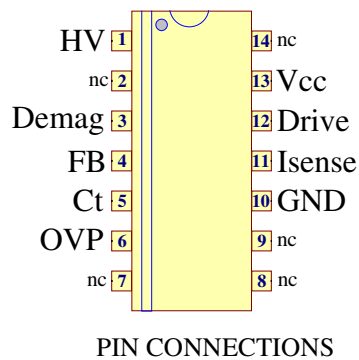





Figure 9-10

			
3101	4822 051 30471	470Ω 5% 0.062W	
3102	4822 051 30332	3k3 5% 0.062W	
3103	4822 051 30331	330Ω 5% 0.062W	
3104	4822 051 30103	10k 5% 0.062W	
3105	4822 051 30332	3k3 5% 0.062W	
3106	4822 051 30333	33k 5% 0.062W	
3107	4822 051 30562	5k6 5% 0.063W RC21 RST SM	
3108	4822 051 30684	680k 5% 0.062W	
3109	4822 051 30103	10k 5% 0.062W	
3130	4822 051 30331	330Ω 5% 0.062W	
3131	4822 051 30103	10k 5% 0.062W	
3132	4822 051 30103	10k 5% 0.062W	
3133	4822 051 30331	330Ω 5% 0.062W	
3134	4822 051 30103	10k 5% 0.062W	
3135	4822 051 30103	10k 5% 0.062W	
3136	4822 051 30221	220Ω 5% 0.062W	
3137	4822 051 30222	2k2 5% 0.062W	
3138	4822 117 12925	47k 1% 0.063W	
3139	4822 051 30102	1k 5% 0.062W	
3140	4822 051 30223	22k 5% 0.062W	
3141	4822 051 30759	75Ω 5% 0.062W	
3142	4822 051 30689	68Ω 5% 0.063W RC21 RST SM	
3143	4822 051 30101	100Ω 5% 0.062W	
3144	4822 051 30331	330Ω 5% 0.062W	
3145	4822 051 30331	330Ω 5% 0.062W	
3146	4822 051 30103	10k 5% 0.062W	
3147	4822 051 30103	10k 5% 0.062W	
3150	4822 051 30471	470Ω 5% 0.062W	
3153	4822 051 30471	470Ω 5% 0.062W	
3154	4822 051 30103	10k 5% 0.062W	
3155	4822 051 30103	10k 5% 0.062W	
3156	4822 051 30221	220Ω 5% 0.062W	
3158	4822 051 30183	18k 5% 0.062W	
3159	4822 051 30103	10k 5% 0.062W	
3160	4822 051 30222	2k2 5% 0.062W	
3161	4822 051 30689	68Ω 5% 0.063W RC21 RST SM	
3162	4822 051 30101	100Ω 5% 0.062W	
3200	4822 051 30479	47Ω 5% 0.062W	
3201	4822 051 30472	4k7 5% 0.062W	
3210	4822 051 30008	0Ω jumper	
3211	5322 117 13026	4k7 1% 0.063W RC22H	
3212	5322 117 13062	390Ω 1% 0.063W RC22H	
3213	5322 117 13026	4k7 1% 0.063W RC22H	
3214	2322 704 62001	RST SM RC22H 200Ω PM1 R	
3215	4822 051 30008	0Ω jumper	
3216	5322 117 13026	4k7 1% 0.063W RC22H	
3217	2322 704 62001	RST SM RC22H 200Ω PM1 R	
3218	5322 117 13062	390Ω 1% 0.063W RC22H	
3219	5322 117 13026	4k7 1% 0.063W RC22H	
3220	4822 051 30331	330Ω 5% 0.062W	
3221	4822 051 30103	10k 5% 0.062W	
3222	4822 051 30103	10k 5% 0.062W	
3223	4822 051 30331	330Ω 5% 0.062W	
3224	4822 051 30331	330Ω 5% 0.062W	
3225	4822 051 30103	10k 5% 0.062W	
3226	4822 051 30103	10k 5% 0.062W	
3230	4822 051 30008	0Ω jumper	
3231	5322 117 13026	4k7 1% 0.063W RC22H	
3232	5322 117 13062	390Ω 1% 0.063W RC22H	
3233	5322 117 13026	4k7 1% 0.063W RC22H	
3234	2322 704 62001	RST SM RC22H 200Ω PM1 R	
3235	4822 051 30008	0Ω jumper	
3236	5322 117 13026	4k7 1% 0.063W RC22H	
3237	2322 704 62001	RST SM RC22H 200Ω PM1 R	
3238	5322 117 13062	390Ω 1% 0.063W RC22H	
3239	5322 117 13026	4k7 1% 0.063W RC22H	
3240	4822 051 30331	330Ω 5% 0.062W	
3241	4822 051 30103	10k 5% 0.062W	
3242	4822 051 30103	10k 5% 0.062W	
3250	4822 051 30008	0Ω jumper	
3251	4822 051 30181	180Ω 5% 0.062W	
3311	4822 051 30103	10k 5% 0.062W	
3320	4822 051 30103	10k 5% 0.062W	
3321	4822 051 30103	10k 5% 0.062W	
3322	4822 051 30102	1k 5% 0.062W	
3330	4822 051 30471	470Ω 5% 0.062W	
3331	4822 051 30331	330Ω 5% 0.062W	
3332	4822 051 30331	330Ω 5% 0.062W	
3333	4822 051 30103	10k 5% 0.062W	
3334	4822 051 30472	4k7 5% 0.062W	
3335	4822 051 30471	470Ω 5% 0.062W	
3336	4822 051 30472	4k7 5% 0.062W	
3341	4822 051 30109	10Ω 5% 0.062W	
3342	4822 051 30109	10Ω 5% 0.062W	
3344	4822 051 30102	1k 5% 0.062W	
3345	4822 051 30102	1k 5% 0.062W	
3346	4822 051 30102	1k 5% 0.062W	
3347	4822 051 30102	1k 5% 0.062W	
3348	4822 051 30472	4k7 5% 0.062W	
3349	4822 051 30472	4k7 5% 0.062W	
3350	4822 051 30472	4k7 5% 0.062W	
3351	4822 051 30472	4k7 5% 0.062W	
3352	4822 051 30472	4k7 5% 0.062W	
3353	4822 051 30472	4k7 5% 0.062W	
3380	4822 051 30109	10Ω 5% 0.062W	
3381	4822 117 13608	4Ω7 5% 0.0062W	
3382	4822 051 30109	10Ω 5% 0.062W	
3383	4822 117 13608	4Ω7 5% 0.0062W	
3403	4822 051 30103	10k 5% 0.062W	
3404	4822 117 12925	47k 1% 0.063W	
3405	4822 051 30563	56k 5% 0.062W	
3406	4822 051 30103	10k 5% 0.062W	
3420	4822 051 30103	10k 5% 0.062W	
3421	4822 051 30472	4k7 5% 0.062W	
3422	4822 051 30472	4k7 5% 0.062W	
3423▲	4822 117 11152	4Ω7 5%	
3424	4822 051 30102	1k 5% 0.062W	
3425	4822 051 30102	1k 5% 0.062W	
3426	4822 051 30102	1k 5% 0.062W	
3427	4822 051 30472	4k7 5% 0.062W	
4303	4822 051 30221	220Ω 5% 0.062W	
			
6101	4822 130 11397	BAS316	
6104	4822 130 11397	BAS316	
6130	4822 130 11522	UDZ15B	
6311	4822 130 11148	UDZ4.7B	
6320	4822 130 11397	BAS316	
6420	9965 000 04709	UDZ6.2BTE-17	
			
7101	4822 130 60511	BC847B	
7102	4822 130 60373	BC856B	
7104	4822 130 60373	BC856B	
7130	4822 130 60511	BC847B	
7131	4822 130 60511	BC847B	
7132	4822 130 60511	BC847B	
7133	4822 130 60511	BC847B	
7134	4822 130 60373	BC856B	
7135	4822 130 60511	BC847B	
7136	4822 130 60511	BC847B	
7150	4822 130 60511	BC847B	
7151	4822 130 60511	BC847B	
7160	4822 130 60511	BC847B	
7200	9322 177 09685	IC SM AK4382AVT (AKM0) R	
7210	4822 209 30095	LM833D	
7220	4822 130 60511	BC847B	
7221	4822 130 60511	BC847B	
7222	4822 130 60511	BC847B	
7223	4822 130 60511	BC847B	
7300	9322 171 86671	IC SM TMP47C416VF (TOSJ) Y	
7310	4822 209 31257	MC79L24ACP	
7320	4822 130 60511	BC847B	
7330	4822 130 40981	BC337-25	
7331	4822 130 41246	BC337-25	
7332	4822 130 60511	BC847B	
7340	9322 155 82667	IR RECEIVER TSOP2236	
7341	9337 140 30653	74HC86D	
7342	4822 130 60511	BC847B	
7380	3139 240 50181	FTD HNV-07SS41T DVD 623	
7400	9322 163 53685	FET POW SM IRLML2502 (INR0) R	
7401	9322 163 53685	FET POW SM IRLML2502 (INR0) R	
7403	4822 130 60511	BC847B	
7420	4822 130 60373	BC856B	
7421	4822 130 60373	BC856B	
7422	9322 163 53685	FET POW SM IRLML2502 (INR0) R	
7423	4822 209 90927	L78L05ACD	
Front Control			
Various			
1500	4822 265 30734	4 PINS	
1510	4822 276 13775	SWITCH	
1520	4822 276 13775	SWITCH	
1530	4822 276 13775	SWITCH	

Front Stby**Various**

1600 2422 025 04849 CON BMT 2P
1610 4822 276 13775 SWITCH